

# LIFTING AND LASHING EQUIPMENT



## LIFTING SLING



This image is protected by under law

U.K. PRODUCTS

Think about  
The Safety of Lifting  
Think of  
TECHNICAL LIFT-ALL

## LASHINGS SYSTEM



This image is protected by under law

U.K. PRODUCTS

The Official Distributor

**MERTRA**<sup>®</sup>

  
**RIBBONS**

B.S.3481



**TECHNICAL LIFT-ALL CO., LTD.**

“The Leadership of Lifting and Lashing Equipment”

Catalog No 2-2022.1 Europe 1999



RIBBONS is one of the leading manufacturers of webbing slings, round slings and cargo-lashings, for use in industry as well as for civil engineering, transportation and shipping.

Production facilities are located in Theorchy factory U.K. and Singapore resulting in fast and accurate world-wide deliveries.

MERTRA webbing sling and roundsling are made in a standard range of types and sizes, designed to meet most lifting needs. Slings are designed to suit specific applications on request.

All MERTRA slings are subject to rigorous quality control at all levels of production from yarn to final assembly. This is an essential factor in the production of high quality slings ensuring high strength, reliability and consistent performance.

MERTRA slings and lashings are certified by the german labour inspectorate (Berufsgenossenschaft) and the belgian AIB Vincotte.



**POLYESTER LIFTING SLING APPLICATIONS**

AIR CONDITIONING UNITS  
 AUTOMOBILES  
 AUTOMOBILE PARTS  
 BALES  
 BEARINGS  
 BOILERS  
 BOAT HANDLING  
 BULK MASTERIALS  
 CONCRETE PIPE  
 DRUMS

ELECTRICAL EQUIPMANT  
 FINISHED PARTS  
 HARBOR-LOADING AND UNLOADING  
 UNLOADING  
 HEATING UNITS  
 JET ENGINES  
 INSTRUMENTS  
 LIGHTING FIXTURES  
 LOGGING  
 MACHINERY AND MACHINED PARTS

NUCLEAR EQUIPMENT  
 OIL DRILLING PARTS  
 PAPER ROLLS  
 PREFAB UNITS  
 PROPELLERS  
 QUENCHING OPERATINGS  
 RADIOACTIVE MATERIALS  
 SALVAGE OPERATIONS  
 SCULPTURES  
 SHAFTS

SIGNS  
 STEEL FACTORY  
 TELEPHONE POLE HANDING  
 TRANSFORMERS  
 TRANSPORTATION  
 VAULTS  
 VENTILATION UNITS  
 WASTE DISPOSAL  
 X-RAY EQUIPMENT  
 YARD LIFTING-RAILAND LUMBER





index

Page

	Webbing Slings with eyes, 25mm. Series	6 - 7
	Webbing Slings with eyes, 30mm. Series	8 - 9
	Webbing Slings Endless	10 - 11
	RE-5 Round Sling Endless	12
	RS-5 Polyester Round Slings with eyes	13
	Extra wide Slings	14 - 15
	Lifting sling with metal component Pipeline sling, Lowering-in Belts	16-17
	Lifting sling for Flat glass	18
	3" Lashing System, Heavy Duty 4" Lashing System, Heavy Duty	20 - 21
	2" Lashing System 6,000 kgs.	22 - 23
	2" Lashing System 5,000 kgs.	24 - 27
	Lashing System with Trailer winch	28
	Strap for Vehicle Transport	29
	1-1/2" Lashing System 3,000 kgs.	30 - 31
	1" Lashing System 1,000 kgs.	32 - 33
	1" Tie Down Strap with Cam Buckle	34

## Safe Operating Practices

- Inspect slings prior to each use and do not use if damaged. (See specific sling type for inspection criteria.)

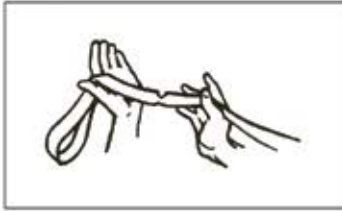

- Slings shall not be loaded in excess of their rated capacities. Rated capacities (Working Load Limits) must be shown by markings or tags attached to all slings.

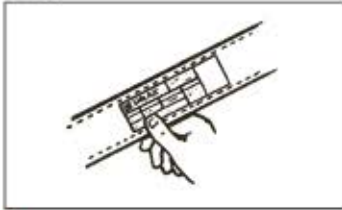

- Angle of lift must be considered in all lifts. See page 10.



- Slings shall be padded or protected from the sharp edges of their loads.



- Loads must be rigged to prevent slippage.

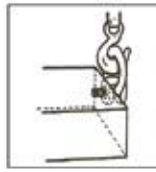

- Slings shall be securely attached to their loads.

- Lift must be stable with respect to the center of gravity - balanced.

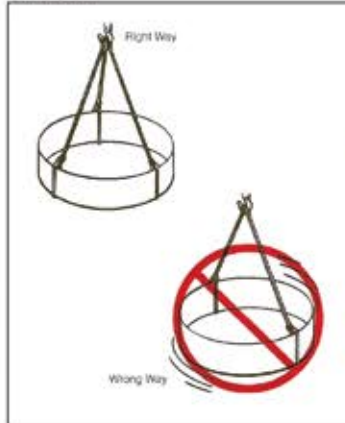

- A sling shall not be pulled from under a load when the load is resting on the sling. Before a load is lifted, a place should be prepared where it is to be put down. Lumber can be used to allow space to remove the sling and prevent shifting of the load.



- Temperature and chemical environment must be considered (see specific sling types for data).



- Slings shall not be shortened with knots, bolts, or makeshift devices.



- Sling legs shall not be knicked or twisted.

- Slings shall not be dragged on floor.



- Slings shall be stored in cool, dark, dry areas, preferably on racks.

- Do not point load hooks - center load in base of hook.



- Hands and fingers shall not be placed between the sling and load while the sling is being tightened around the load. After lifting, the load should not be pushed or guided by employees hands directly on the load. Ropes or "tag lines" should be attached for this purpose.

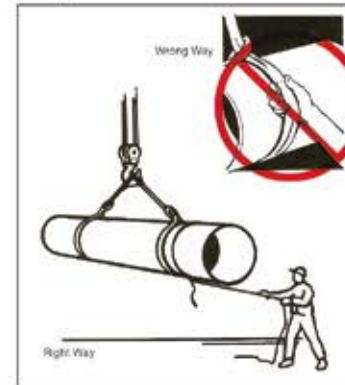

- Suspended loads shall be kept clear of all obstructions.
- All persons shall be kept clear of loads to be lifted, and suspended load.



- Do not shock load. Jerking the load could overload the sling and cause it to fail.

## INSPECTION CRITERIA

### WARNING Read Defector on page 3

#### Inspection Criteria for Synthetic Web Slings Refer to illustrations of damaged webbing

Remove from service if any of the following is visible:

- Capacity tag is missing or illegible
- Red core warning yarns are visible
- Sling shows signs of melting, charring or chemical damage
- End fittings are excessively pitted, corroded, distorted, cracked or broken
- Cuts on the face or edge of webbing
- Holes, tears, snags or crushed web
- Signs of excessive abrasive wear
- Broken or worn threads in the stitch patterns
- Any other visible damage which causes doubt as to its strength

**Red Core Yarns** - warn of dangerous sling damage. All Lift All Nylon or Polyester Web Slings shown in this section of the catalog have this warning feature. When red yarns are visible, the sling should be removed from service immediately. The red core yarns become exposed when the sling surface is cut or worn through the woven face yarns. For other inspection criteria see OSHA/Manufacturer regulations on pages 6 through 11.

#### Examples of Web Sling Abuse

Most of the damage shown here would cause immediate catastrophic failure of the sling. Not all of the damage you will see will be this obvious or extreme, but still requires removal from use.

**Elasticity** - The stretch characteristics of web slings depends on the type of yarn and the web finish. Approximate stretch at RATED SLING CAPACITY is:

	NYLON	POLYESTER
Treated	10%	7%
Untreated	6%	3%

Prior to sling selection and use, review and understand the "Help" section.

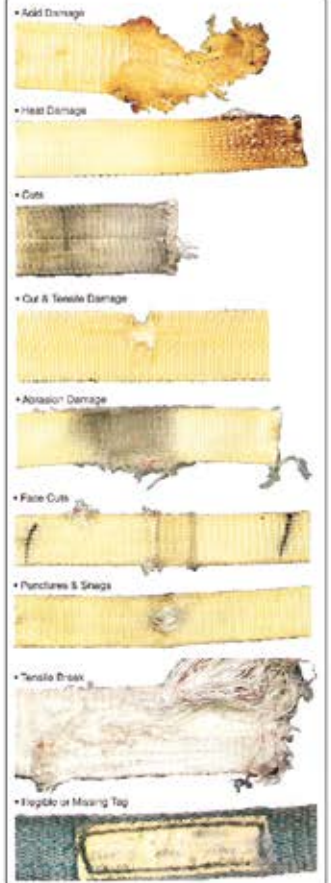



# MERTRA®

## Lifting Sling Polyester



*Lifting sling are produced from controlled high tenacity polyester yarns.*

**FEATURE :**

- Double ply polyester webbing sling with reinforced lifting eyes.
- Working load limit WLL. 1-12 Tonne, Length 1-50 Mtr.

**SPECIFICATIONS :**

- Sling are constructed of 100% polyester
- Certified standard DIN V 61360 Show at blue label
- Safety factor 7:1
- Each kg class has its own colour code. ( see technical data )
- Max. working temp. 100°C ( 200°F ) Melting point 260°C ( 500°F )
- Excellant resistant to acids, oil, ultra violet ray, rot and mildew.
- Lightweight easy to handle, store and clean.
- No less of strength in water.
- Only 3% elongation.

**NORMS**

- According to Machine Directive 89/392/EC.



Europe/EEC

**MERTRA®**

**WS-2/25 Series**

Lifting sling are manufactured to international standards.



**MERTRA® Chemical resistance information chart**

material	acids	alkalis	oils	organic solvents	water and seawater	ethers	aldehydes	alcohols
Polyester	ok*	no	ok	ok	ok	no	no	ok

\* designtegrated by concentrated sulfuric acid. Higher chemical concentrations and/or higher temperratures will lower the resistance of the sling.

**TECHNICAL DATA, 25 mm. Series**

webbing width (mm)	Colourcode according to DIN-EN 1492-1		Working Load Limits with 1 webbing sling					Working Load Limits with 2 webbing slings			
			straight lift	choked lift	β			straght lift up to 45°	choked lift up to 45°	straght lift 45°- 60°	choked lift 45°-60°
					0°- 7°	7°- 45°	45°- 60°				
			1,0	0,8	2,0	1,4	1,0	1,4	1,12	1,0	0,8
25	WLL 1 T	Violet	1,000	800	2,000	1,400	1,000	1,400	1,120	1,000	800
50	WLL 2 T	Green	2,000	1,600	4,000	2,800	2,000	2,800	2,240	2,000	1,600
75	WLL 3 T	Yellow	3,000	2,400	6,000	4,200	3,000	4,200	3,360	3,000	2,400
100	WLL 4 T	Grey	4,000	3,200	8,000	5,600	4,000	5,600	4,480	4,000	3,200
125	WLL 5 T	Red	5,000	4,000	10,000	7,000	5,000	7,000	5,600	5,000	4,000
150	WLL 6 T	Brown	6,000	4,800	12,000	8,400	6,000	8,400	6,720	6,000	4,800
200	WLL 8 T	Blue	8,000	6,400	16,000	11,200	8,000	11,200	8,960	8,000	6,400
250	WLL 10 T	Orange	10,000	8,000	20,000	14,000	10,000	14,000	11,200	10,000	8,000
300	WLL 12 T	Orange	12,000	9,600	24,000	16,800	12,000	16,800	13,440	12,000	9,600

**MERTRA® lifting eye types**

1. Flat eye
2. Reversed eye
3. Folded eye 1/2 width from 1 side
4. Folded eye 1/2 width from 2 sides
5. Folded eye 1/3 width



**CAUTIONS**

- Do not exceed Working Load Limited
- Prevent shock-loading.
- When selecting a sling it is very important consider the angles at which the sling will be used.
- Sling are subject to cutting when lifting items with sharp edges. In this case always use wear sleeves.
- Do not use a damaged sling.
- Never drag a sling from underneath a load that is resting on it.
- Chemical active environments can effect the strength of slings.
- Operating temperature range: -40°C to + 100°C.
- Inspect slings weekly or more frequently depending on sling use.
- Always store slings in a cool dry and dark place when they are not in use for prolonged periods.
- Always read and understand the operating instructions before use.



**MERTRA® WS-1 Polyester single-ply webbing slings**

**FEATURE :**

- Single-ply polyester webbing sling with reinforced lifting eyes.
- Working load limit WLL. 0.5-6 Tonne, Length 1-20 Mtr.
- Safety Factor ( S/F ) 7:1

**MERTRA®**

**WS-1/25 Series**

Lifting sling are manufactured to international standards.



webbing width (mm)	Colourcode according to DIN-EN 1492-1		Working Load Limits with 1 webbing sling					Working Load Limits with 2 webbing slings			
			straight lift	choked lift	β			straght lift up to 45°	choked lift up to 45°	straght lift 45°- 60°	choked lift 45°-60°
					0°- 7°	7°- 45°	45°- 60°				
			1,0	0,8	2,0	1,4	1,0	1,4	1,12	1,0	0,8
25	WLL 0.5 T	Violet	500	400	1,000	700	500	700	560	500	400
50	WLL 1 T	Green	1,000	800	2,000	1,400	1,000	1,400	1,120	1,000	800
75	WLL 1.5 T	Yellow	1,500	1,200	3,000	2,100	1,500	2,100	1,680	1,500	1,200
100	WLL 2 T	Grey	2,000	1,600	4,000	2,800	2,000	2,800	2,240	2,000	1,600
125	WLL 2.5 T	Red	2,500	2,000	5,000	3,500	2,500	3,500	2,800	2,500	2,000
150	WLL 3 T	Brown	3,000	2,400	6,000	4,200	3,000	4,200	3,360	3,000	2,400
200	WLL 4 T	Blue	4,000	3,200	8,000	5,600	4,000	5,600	4,480	4,000	3,200
250	WLL 5 T	Orange	5,000	4,000	10,000	7,000	5,000	7,000	5,600	5,000	4,000
300	WLL 6 T	Orange	6,000	4,800	12,000	8,400	6,000	8,400	6,720	6,000	4,800

Type WS-1

**MERTRA® WS-4 Polyester 4-ply webbing slings**

**FEATURE :**

- 4-ply polyester webbing sling with reinforced lifting eyes.
- Working load limit WLL. 2-24 Tonne, Length 1-20 Mtr.
- Safety Factor ( S/F ) 7:1

**MERTRA®**

**WS-4/25 Series**

Lifting sling are manufactured to international standards.



webbing width (mm)	Colourcode according to DIN-EN 1492-1		Working Load Limits with 1 webbing sling					Working Load Limits with 2 webbing slings			
			straight lift	choked lift	β			straght lift up to 45°	choked lift up to 45°	straght lift 45°- 60°	choked lift 45°-60°
					0°- 7°	7°- 45°	45°- 60°				
			1,0	0,8	2,0	1,4	1,0	1,4	1,12	1,0	0,8
25	WLL 2 T	Violet	2,000	1,600	4,000	2,800	2,000	2,800	2,240	2,000	1,600
50	WLL 4 T	Green	4,000	3,200	8,000	5,600	4,000	5,600	4,480	4,000	3,200
75	WLL 6 T	Yellow	6,000	4,800	12,000	8,400	6,000	8,400	6,720	6,000	4,800
100	WLL 8 T	Grey	8,000	6,400	16,000	11,200	8,000	11,200	8,960	8,000	6,400
125	WLL 10 T	Red	10,000	8,000	20,000	14,000	10,000	14,000	11,200	10,000	8,000
150	WLL 12 T	Brown	12,000	9,600	24,000	16,800	12,000	16,800	13,440	12,000	9,600
200	WLL 16 T	Blue	16,000	12,800	32,000	22,400	16,000	22,400	17,920	16,000	12,800
250	WLL 20 T	Orange	20,000	16,000	40,000	28,000	20,000	28,000	22,400	20,000	16,000
300	WLL 24 T	Orange	24,000	19,200	48,000	33,600	24,000	33,600	26,880	24,000	19,200

Type WS-4

**FEATURE :**

- Double ply polyester webbing sling with reinforced lifting eyes.
- Working load limit WLL. 1-10 Tonne, Length 1-50 Mtr.

**SPECIFICATIONS :**

- Sling are constructed of 100% polyester
- Certified standard DIN V 61360 Show at blue label
- Safety factor 7:1
- Each kg class has its own colour code. ( see technical data )
- Black Stips to indentify WLL each tonne.
- Max. working temp. 100°C ( 200°F ) Melting point 260°C ( 500°F )
- Excellant resistant to acids, oil, ultra violet ray, rot and mildew.
- Lightweight easy to handle, store and clean.
- No less of strength in water.
- Only 3% elongation.

**NORMS**

- According to Machine Directive 89/392/EC.



Europe/EEC

**MERTRA®**

**WS-2/30 Series**

Lifting sling are manufactured to international standards.



**MERTRA® Chemical resistance information chart**

material	acids	alkalis	oils	organic solvents	water and seawater	ethers	aldehydes	alcohols
Polyester	ok*	no	ok	ok	ok	no	no	ok

\* designtegrated by concentrated sulfuric acid. Higher chemical concentrations and/or higher tempratures will lower the resistance of the sling.

**TECHNICAL DATA, 30 mm. Series**

webbing width (mm) / Strip	Colourcode according to DIN-EN 1492-1	Working Load Limits with 1 webbing sling					Working Load Limits with 2 webbing slings			
		straight lift	choked lift	β			straght lift up to 45°	choked lift up to 45°	straght lift 45°- 60°	choked lift 45°-60°
				0°- 7°	7°- 45°	45°- 60°				
		1,0	0,8	2,0	1,4	1,0	1,4	1,12	1,0	0,8
30	WLL 1 T Violet	1,000	800	2,000	1,400	1,000	1,400	1,120	1,000	800
60	WLL 2 T Green	2,000	1,600	4,000	2,800	2,000	2,800	2,240	2,000	1,600
90	WLL 3 T Yellow	3,000	2,400	6,000	4,200	3,000	4,200	3,360	3,000	2,400
120	WLL 4 T Grey	4,000	3,200	8,000	5,600	4,000	5,600	4,480	4,000	3,200
150	WLL 5 T Red	5,000	4,000	10,000	7,000	5,000	7,000	5,600	5,000	4,000
180	WLL 6 T Brown	6,000	4,800	12,000	8,400	6,000	8,400	6,720	6,000	4,800
240	WLL 8 T Blue	8,000	6,400	16,000	11,200	8,000	11,200	8,960	8,000	6,400
300	WLL 10 T Orange	10,000	8,000	20,000	14,000	10,000	14,000	11,200	10,000	8,000

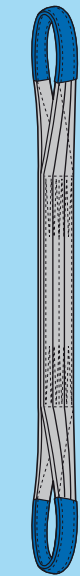

Type WS-2

- The eyes are reinforced. They act as protection between the sling and the hook. Friction is reduced.
- The eyes of the lifting slings are folded or becketted ( see detail ).
- A label is sewn into each sling from which the allowed direct lift load in kg and the effect of various angles on lifting capacity can be seen.
- Each kg classification has its own colour code.
- Woven in identification black strip ( up to 10,000 kg ) show the working load limit WLL
- Corner pads must be used when lifting loads with sharp edges ( option ).
- Slings are given a durable coating in order to increase resistance against abrasion.



**MERTRA® WS-1 Polyester single-ply webbing slings**

**MERTRA®**

**WS-1/30 Series**

Lifting sling are manufactured to international standards.



**FEATURE :**

- Single-ply polyester webbing sling with reinforced lifting eyes.
- Working load limit WLL. 0.5-5 Tonne, Length 1-20 Mtr.
- Safety Factor ( S/F ) 7:1

webbing width (mm) / Strip	Colourcode according to DIN-EN 1492-1		Working Load Limits with 1 webbing sling					Working Load Limits with 2 webbing slings			
			straight lift	choked lift	β			straght lift up to 45°	choked lift up to 45°	straght lift 45°- 60°	choked lift 45°-60°
					0°- 7°	7°- 45°	45°- 60°				
			1,0	0,8	2,0	1,4	1,0	1,4	1,12	1,0	0,8
30 —	WLL 0.5 T	Violet	500	400	1,000	700	500	700	560	500	400
60 ==	WLL 1 T	Green	1,000	800	2,000	1,400	1,000	1,400	1,120	1,000	800
90 ==	WLL 1.5 T	Yellow	1,500	1,200	3,000	2,100	1,500	2,100	1,680	1,500	1,200
120 ==	WLL 2 T	Grey	2,000	1,600	4,000	2,800	2,000	2,800	2,240	2,000	1,600
150 ==	WLL 2.5 T	Red	2,500	2,000	5,000	3,500	2,500	3,500	2,800	2,500	2,000
180 ==	WLL 3 T	Brown	3,000	2,400	6,000	4,200	3,000	4,200	3,360	3,000	2,400
240 ==	WLL 4 T	Blue	4,000	3,200	8,000	5,600	4,000	5,600	4,480	4,000	3,200
300 ==	WLL 5 T	Orange	5,000	4,000	10,000	7,000	5,000	7,000	5,600	5,000	4,000

Type WS-1

**MERTRA® WS-4 Polyester 4-ply webbing slings**

**MERTRA®**

**WS-4/30 Series**

Lifting sling are manufactured to international standards.



**FEATURE :**

- 4-ply polyester webbing sling with reinforced lifting eyes.
- Working load limit WLL. 2-20 Tonne, Length 1-20 Mtr.
- Safety Factor ( S/F ) 7:1

webbing width (mm) / Strip	Colourcode according to DIN-EN 1492-1		Working Load Limits with 1 webbing sling					Working Load Limits with 2 webbing slings			
			straight lift	choked lift	β			straght lift up to 45°	choked lift up to 45°	straght lift 45°- 60°	choked lift 45°-60°
					0°- 7°	7°- 45°	45°- 60°				
			1,0	0,8	2,0	1,4	1,0	1,4	1,12	1,0	0,8
30 —	WLL 2 T	Violet	2,000	1,600	4,000	2,800	2,000	2,800	2,240	2,000	1,600
60 ==	WLL 4 T	Green	4,000	3,200	8,000	5,600	4,000	5,600	4,480	4,000	3,200
90 ==	WLL 6 T	Yellow	6,000	4,800	12,000	8,400	6,000	8,400	6,720	6,000	4,800
120 ==	WLL 8 T	Grey	8,000	6,400	16,000	11,200	8,000	11,200	8,960	8,000	6,400
150 ==	WLL 10 T	Red	10,000	8,000	20,000	14,000	10,000	14,000	11,200	10,000	8,000
180 ==	WLL 12 T	Brown	12,000	9,600	24,000	16,800	12,000	16,800	13,440	12,000	9,600
240 ==	WLL 16 T	Blue	16,000	12,800	32,000	22,400	16,000	22,400	17,920	16,000	12,800
300 ==	WLL 20 T	Orange	20,000	16,000	40,000	28,000	20,000	28,000	22,400	20,000	16,000

Type WS-4

**MERTRA® WE-1 Polyester single-ply webbing slings,  
25 mm. Series**

**TYPE :**

- Single-ply polyester webbing sling endless.
- Working load limit WLL. 1-12 Tonne, Length 1-20 Mtr.
- Safety Factor ( S/F ) 7:1

**MERTRA®**

**WE-1/25 Series**

Lifting sling are manufactured  
to international standards.

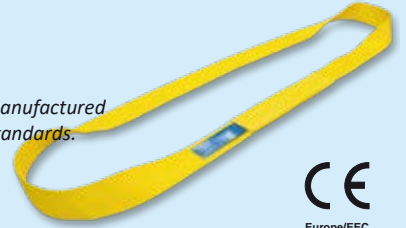

webbing width (mm)	Colourcode according to DIN-EN 1492-1		Working Load Limits with 1 webbing sling					Working Load Limits with 2 webbing slings			
			straight lift	choked lift	β			straght lift up to 45°	choked lift up to 45°	straght lift 45°- 60°	choked lift 45°-60°
					0°- 7°	7°- 45°	45°- 60°				
			1,0	0,8	2,0	1,4	1,0	1,4	1,12	1,0	0,8
25	WLL 1 T	Violet	1,000	800	2,000	1,400	1,000	1,400	1,120	1,000	800
50	WLL 2 T	Green	2,000	1,600	4,000	2,800	2,000	2,800	2,240	2,000	1,600
75	WLL 3 T	Yellow	3,000	2,400	6,000	4,200	3,000	4,200	3,360	3,000	2,400
100	WLL 4 T	Grey	4,000	3,200	8,000	5,600	4,000	5,600	4,480	4,000	3,200
125	WLL 5 T	Red	5,000	4,000	10,000	7,000	5,000	7,000	5,600	5,000	4,000
150	WLL 6 T	Brown	6,000	4,800	12,000	8,400	6,000	8,400	6,720	6,000	4,800
200	WLL 8 T	Blue	8,000	6,400	16,000	11,200	8,000	11,200	8,960	8,000	6,400
250	WLL 10 T	Orange	10,000	8,000	20,000	14,000	10,000	14,000	11,200	10,000	8,000
300	WLL 12 T	Orange	12,000	9,600	24,000	16,800	12,000	16,800	13,440	12,000	9,600

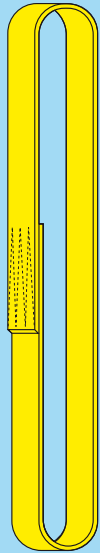

Type WE-1

**MERTRA® WE-2 Polyester double-ply webbing slings,  
25 mm. Series**

**TYPE :**

- Double-ply polyester webbing sling endless.
- Working load limit WLL. 2-24 Tonne, Length 1-20 Mtr.
- Safety Factor ( S/F ) 7:1

**MERTRA®**

**WE-2/25 Series**

Lifting sling are manufactured  
to international standards.



webbing width (mm)	Colourcode according to DIN-EN 1492-1		Working Load Limits with 1 webbing sling					Working Load Limits with 2 webbing slings			
			straight lift	choked lift	β			straght lift up to 45°	choked lift up to 45°	straght lift 45°- 60°	choked lift 45°-60°
					0°- 7°	7°- 45°	45°- 60°				
			1,0	0,8	2,0	1,4	1,0	1,4	1,12	1,0	0,8
25	WLL 2 T	Violet	2,000	1,600	4,000	2,800	2,000	2,800	2,240	2,000	1,600
50	WLL 4 T	Green	4,000	3,200	8,000	5,600	4,000	5,600	4,480	4,000	3,200
75	WLL 6 T	Yellow	6,000	4,800	12,000	8,400	6,000	8,400	6,720	6,000	4,800
100	WLL 8 T	Grey	8,000	6,400	16,000	11,200	8,000	11,200	8,960	8,000	6,400
125	WLL 10 T	Red	10,000	8,000	20,000	14,000	10,000	14,000	11,200	10,000	8,000
150	WLL 12 T	Brown	12,000	9,600	24,000	16,800	12,000	16,800	13,440	12,000	9,600
200	WLL 16 T	Blue	16,000	12,800	32,000	22,400	16,000	22,400	17,920	16,000	12,800
250	WLL 20 T	Orange	20,000	16,000	40,000	28,000	20,000	28,000	22,400	20,000	16,000
300	WLL 24 T	Orange	24,000	19,200	48,000	33,600	24,000	33,600	26,880	24,000	19,200

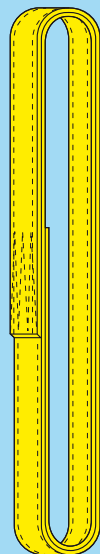

Type WE-2



MERTRA® WE-1 Polyester single-ply webbing slings,  
30 mm. Series

TYPE :

- Single-ply polyester webbing sling endless.
- Working load limit WLL. 1-10 Tonne, Length 1-20 Mtr.
- Safety Factor ( S/F ) 7:1

MERTRA®

WE-1/30 Series

Lifting sling are manufactured  
to international standards.

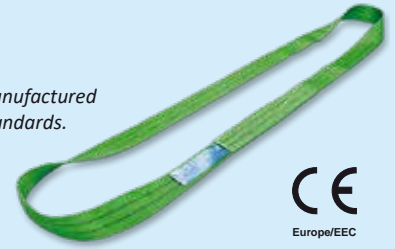

webbing width (mm) / Strip	Colourcode according to DIN-EN 1492-1		Working Load Limits with 1 webbing sling					Working Load Limits with 2 webbing slings			
			straight lift	choked lift	β			straght lift up to 45°	choked lift up to 45°	straght lift 45°- 60°	choked lift 45°-60°
					0° - 7°	7° - 45°	45° - 60°				
			1,0	0,8	2,0	1,4	1,0	1,4	1,12	1,0	0,8
30 —	WLL 1 T	Violet	1,000	800	2,000	1,400	1,000	1,400	1,120	1,000	800
60 ==	WLL 2 T	Green	2,000	1,600	4,000	2,800	2,000	2,800	2,240	2,000	1,600
90 ===	WLL 3 T	Yellow	3,000	2,400	6,000	4,200	3,000	4,200	3,360	3,000	2,400
120 ====	WLL 4 T	Grey	4,000	3,200	8,000	5,600	4,000	5,600	4,480	4,000	3,200
150 =====	WLL 5 T	Red	5,000	4,000	10,000	7,000	5,000	7,000	5,600	5,000	4,000
180 =====	WLL 6 T	Brown	6,000	4,800	12,000	8,400	6,000	8,400	6,720	6,000	4,800
240 =====	WLL 8 T	Blue	8,000	6,400	16,000	11,200	8,000	11,200	8,960	8,000	6,400
300 =====	WLL 10 T	Orange	10,000	8,000	20,000	14,000	10,000	14,000	11,200	10,000	8,000

Type WE-1

MERTRA® WE-2 Polyester Double-ply webbing slings,  
30 mm. Series

TYPE :

- Double-ply polyester webbing sling endless.
- Working load limit WLL. 2-20 Tonne, Length 1-20 Mtr.
- Safety Factor ( S/F ) 7:1

MERTRA®

WE-2/30 Series

Lifting sling are manufactured  
to international standards.



webbing width (mm) / Strip	Colourcode according to DIN-EN 1492-1		Working Load Limits with 1 webbing sling					Working Load Limits with 2 webbing slings			
			straight lift	choked lift	β			straght lift up to 45°	choked lift up to 45°	straght lift 45°- 60°	choked lift 45°-60°
					0° - 7°	7° - 45°	45° - 60°				
			1,0	0,8	2,0	1,4	1,0	1,4	1,12	1,0	0,8
30 —	WLL 2 T	Violet	2,000	1,600	4,000	2,800	2,000	2,800	2,240	2,000	1,600
60 ==	WLL 4 T	Green	4,000	3,200	8,000	5,600	4,000	5,600	4,480	4,000	3,200
90 ===	WLL 6 T	Yellow	6,000	4,800	12,000	8,400	6,000	8,400	6,720	6,000	4,800
120 ====	WLL 8 T	Grey	8,000	6,400	16,000	11,200	8,000	11,200	8,960	8,000	6,400
150 =====	WLL 10 T	Red	10,000	8,000	20,000	14,000	10,000	14,000	11,200	10,000	8,000
180 =====	WLL 12 T	Brown	12,000	9,600	24,000	16,800	12,000	16,800	13,440	12,000	9,600
240 =====	WLL 16 T	Blue	16,000	12,800	32,000	22,400	16,000	22,400	17,920	16,000	12,800
300 =====	WLL 20 T	Orange	20,000	16,000	40,000	28,000	20,000	28,000	22,400	20,000	16,000

Type WE-2



**MERTRA®**

**RE-5**  
Round sling are manufactured and tested according to international standards.

**FEATURE :**

- Polyester roundsling with two ply woven heavy-duty sleeve.
- Round sling endless.
- Working load limith WLL. 1-100 Tonne, Length 1-24 Mtr.

**SPECIFICATIONS :**

- Sling are constructed of 100% polyester.
- Certified standard DIN V 61360 Show at blue label
- Safety factor 8:1
- The load bearing yarns are protected by a double layer seamless polyester cover.
- Only 3% elongation.

**NORMS**

- According to Machine Directive 89/392/EC.

**TECHNICAL DATA**

type	Colourcode according to DIN-EN 1492-1		Working Load Limits with 1 round sling							Working Load Limits with 2 round slings			
			straight lift	choked lift	0°- 7°	β				straght lift up to 45°	choked lift up to 45°	straght lift 45°- 60°	choked lift 45°- 60°
						bis 7°	7°- 45°	45°- 60°	45°- 60°				
			1,0	0,8	2,0	1,4	1,0	0,7	0,5	1,4	1,12	1,0	0,8
RE-5/01	WLL 1 T	Violet	1,000	800	2,000	1,400	1,000	700	500	1,400	1,120	1,000	800
RE-5/02	WLL 2 T	Green	2,000	1,600	4,000	2,800	2,000	2,000	1,000	2,800	2,240	2,000	1,600
RE-5/03	WLL 3 T	Yellow	3,000	2,400	6,000	4,200	3,000	2,100	1,500	4,200	3,360	3,000	2,400
RE-5/04	WLL 4 T	Grey	4,000	3,200	8,000	5,600	4,000	2,800	2,000	5,600	4,480	4,000	3,200
RE-5/05	WLL 5 T	Red	5,000	4,000	10,000	7,000	5,000	3,500	2,500	7,000	5,600	5,000	4,000
RE-5/06	WLL 6 T	Brown	6,000	4,800	12,000	8,400	6,000	4,200	3,000	8,400	6,720	6,000	4,800
RE-5/08	WLL 8 T	Blue	8,000	6,400	16,000	11,200	8,000	5,600	4,000	11,200	8,960	8,000	6,400
RE-5/10	WLL 10 T	Orange	10,000	8,000	20,000	14,000	10,000	7,000	5,000	14,000	11,200	10,000	8,000
RE-5/12	WLL 12 T	Orange	12,000	9,600	24,000	16,800	12,000	8,400	6,000	16,800	13,440	12,000	9,600
RE-5/15	WLL 15 T	Orange	15,000	12,000	30,000	21,000	15,000	10,500	7,500	21,000	16,800	15,000	12,000
RE-5/20	WLL 20 T	Orange	20,000	16,000	40,000	28,000	20,000	14,000	10,000	28,000	22,400	20,000	16,000
RE-5/25	WLL 25 T	Orange	25,000	20,000	50,000	35,000	25,000	17,500	12,500	35,000	28,000	25,000	20,000
RE-5/30	WLL 30 T	Orange	30,000	24,000	60,000	42,000	30,000	21,000	15,000	42,000	33,600	30,000	24,000
RE-5/40	WLL 40 T	Orange	40,000	32,000	80,000	56,000	40,000	28,000	20,000	56,000	44,800	40,000	32,000
RE-5/50	WLL 50 T	Orange	50,000	40,000	100,000	70,000	50,000	35,000	25,000	70,000	56,000	50,000	40,000
RE-5/60	WLL 60 T	Orange	60,000	48,000	120,000	84,000	60,000	42,000	30,000	84,000	67,200	60,000	48,000
RE-5/80	WLL 80 T	Orange	80,000	64,000	160,000	112,000	80,000	56,000	40,000	112,000	89,600	80,000	64,000
RE-5/100	WLL 100 T	Orange	100,000	80,000	200,000	140,000	100,000	70,000	50,000	140,000	112,000	100,000	80,000

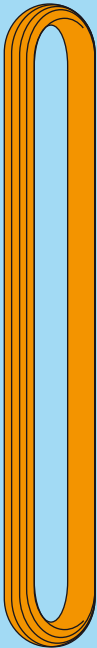

Type RE-5

**1** Each kg class has its own colour code. Woven in identification stripes ( up to 10,000 kg ) Show the working load limit WLL

**2** The kg load class stamped on the round sling shows the allowed direct lift.

**3** Corner pads used when lifting sharp edged loads ( option ).

**4** A label is sewn into each sling from which the allowed direct lift load and the effect of various angles on lifting capacity can be seen.

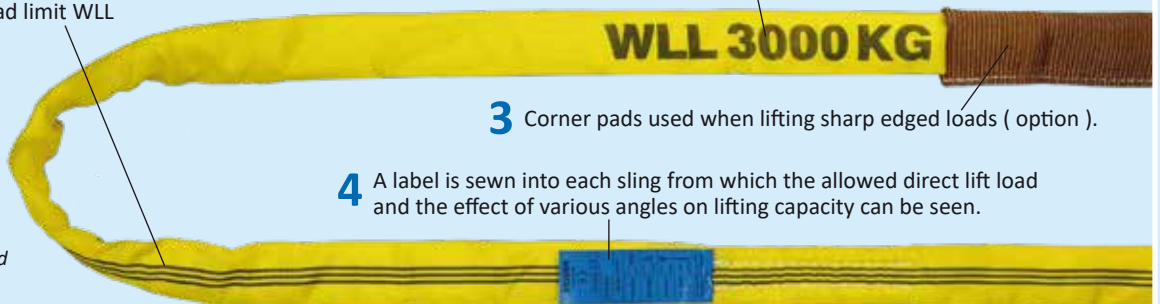

**MERTRA®**

**RE-5**  
Round sling are manufactured and tested according to international standards.



**MERTRA® RS-5 Polyester round slings with eyes**

**TYPE :**

- Round strop sling polyester with eyes
- Working load limit WLL. 1-100 Tonne,  
Length 1-24 Mtr.
- Safety Factor ( S/F ) 8:1



**MERTRA®**

**RS-5**

Round sling are manufactured  
and tested according to international standards.

**TECHNICAL DATA**

type	Colourcode according to DIN-EN 1492-1		Working Load Limits with 1 round sling					Working Load Limits with 2 round slings			
			straight lift	choked lift	U	β		straght lift up to 45°	choked lift up to 45°	straght lift 45° - 60°	choked lift 45° - 60°
						bis 7°	7° - 45°				
			1,0	0,8	2,0	1,4	1,0	1,4	1,12	1,0	0,8
RS-5/01	WLL 1 T	Violet	1,000	800	2,000	1,400	1,000	1,400	1,120	1,000	800
RS-5/02	WLL 2 T	Green	2,000	1,600	4,000	2,800	2,000	2,800	2,240	2,000	1,600
RS-5/03	WLL 3 T	Yellow	3,000	2,400	6,000	4,200	3,000	4,200	3,360	3,000	2,400
RS-5/04	WLL 4 T	Grey	4,000	3,200	8,000	5,600	4,000	5,600	4,480	4,000	3,200
RS-5/05	WLL 5 T	Red	5,000	4,000	10,000	7,000	5,000	7,000	5,600	5,000	4,000
RS-5/06	WLL 6 T	Brown	6,000	4,800	12,000	8,400	6,000	8,400	6,720	6,000	4,800
RS-5/08	WLL 8 T	Blue	8,000	6,400	16,000	11,200	8,000	11,200	8,960	8,000	6,400
RS-5/10	WLL 10 T	Orange	10,000	8,000	20,000	14,000	10,000	14,000	11,200	10,000	8,000
RS-5/12	WLL 12 T	Orange	12,000	9,600	24,000	16,800	12,000	16,800	13,440	12,000	9,600
RS-5/15	WLL 15 T	Orange	15,000	12,000	30,000	21,000	15,000	21,000	16,800	15,000	12,000
RS-5/20	WLL 20 T	Orange	20,000	16,000	40,000	28,000	20,000	28,000	22,400	20,000	16,000
RS-5/25	WLL 25 T	Orange	25,000	20,000	50,000	35,000	25,000	35,000	28,000	25,000	20,000
RS-5/30	WLL 30 T	Orange	30,000	24,000	60,000	42,000	30,000	42,000	33,600	30,000	24,000
RS-5/40	WLL 40 T	Orange	40,000	32,000	80,000	56,000	40,000	56,000	44,800	40,000	32,000
RS-5/50	WLL 50 T	Orange	50,000	40,000	100,000	70,000	50,000	70,000	56,000	50,000	40,000
RS-5/60	WLL 60 T	Orange	60,000	48,000	120,000	84,000	60,000	84,000	67,200	60,000	48,000
RS-5/80	WLL 80 T	Orange	80,000	64,000	160,000	112,000	80,000	112,000	89,600	80,000	64,000
RS-5/100	WLL 100 T	Orange	100,000	80,000	200,000	140,000	100,000	140,000	112,000	100,000	80,000

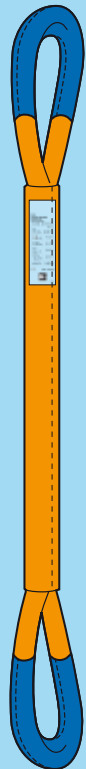

Type RS-5



**MERTRA®**

**RE-5**

Round sling are produced from controlled  
high tenacity polyester yarns.

RE-5 roundsling with 2-ply woven heavy-duty sleeve The roundsling inner core is made from high tensile polyester fibre which is wound continuously without a join to provide the maximum possible strength. This core is protected by a tough woven tubular sleeve also made from polyester without side stitch. It serves to protect both the inner core of the sling and the surface of the product which is lifting.



**MERTRA®**





**RS-5**

Round stop sling with eyes,  
Heavy duty

**MERTRA® CW-1/25 Polyester Single-ply Extra wide slings,  
25 mm. Series, for Heavy Loads**

**TYPE :**

- Single-ply polyester webbing sling.
- Working load limit WLL. 1-12 Tonne, Length 1-20 Mtr.
- Safety Factor ( S/F ) 7:1

webbing width (mm)	Colourcode according to DIN-EN 1492-1		Working Load Limits with 1 webbing sling			
			straight lift	β		
				0°- 7°	7°- 45°	45°- 60°
						
			1,0	2,0	1,4	1,0
50	WLL 1 T	Violet	1,000	2,000	1,400	1,000
100	WLL 2 T	Green	2,000	4,000	2,800	2,000
150	WLL 3 T	Yellow	3,000	6,000	4,200	3,000
200	WLL 4 T	Grey	4,000	8,000	5,600	4,000
250	WLL 5 T	Red	5,000	10,000	7,000	5,000
300	WLL 6 T	Brown	6,000	12,000	8,400	6,000
400	WLL 8 T	Blue	8,000	16,000	11,200	8,000
500	WLL 10 T	Orange	10,000	20,000	14,000	10,000
600	WLL 12 T	Orange	12,000	24,000	16,800	12,000



**Continuous Eye Wide-Lift**

**For Heavy Loads -** Constructed from one endless sling with the two body lengths butted and joined side by side.

**MERTRA®**

**CW-1/25 Series**

Lifting sling are manufactured to international standards.







**MERTRA®**  
**CW-1/30 Series**



**MERTRA® CW-1/30 Polyester Single-ply Extra wide slings,  
30 mm. Series, for Heavy Loads**

**TYPE :**

- Single-ply polyester webbing sling.
- Working load limit WLL. 1-10 Tonne, Length 1-20 Mtr.
- Safety Factor ( S/F ) 7:1

webbing width (mm)	Colourcode according to DIN-EN 1492-1		Working Load Limits with 1 webbing sling			
			straight lift	β		
				0°- 7°	7°- 45°	45°- 60°
						
			1,0	2,0	1,4	1,0
60	WLL 1 T	Violet	1,000	2,000	1,400	1,000
120	WLL 2 T	Green	2,000	4,000	2,800	2,000
180	WLL 3 T	Yellow	3,000	6,000	4,200	3,000
240	WLL 4 T	Grey	4,000	8,000	5,600	4,000
300	WLL 5 T	Red	5,000	10,000	7,000	5,000
360	WLL 6 T	Brown	6,000	12,000	8,400	6,000
480	WLL 8 T	Blue	8,000	16,000	11,200	8,000
600	WLL 10 T	Orange	10,000	20,000	14,000	10,000





MERTRA® AW-1/25 Polyester single-ply Extra wide slings,  
25 mm. Series, for light, Bulky Loads.

TYPE :

- Single-ply polyester webbing sling.
- Working load limit WLL. 1-6 Tonne, Length 1-20 Mtr.
- Safety Factor ( S/F ) 7:1

Attached Eye Wide-Lift

For light, Bulky Loads

- Lifting eyes are attached to a single ply sling body.

Available with One Ply eyes (WS) or TWO PLY eyes (WD).

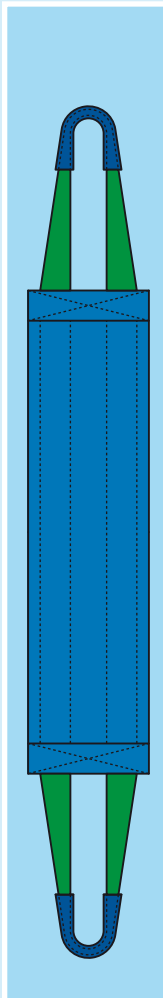

Type AW-1

webbing width (mm)	Colourcode according to DIN-EN 1492-1		Working Load Limits with 1 webbing sling			
			straight lift	β		
				0°- 7°	7°- 45°	45°- 60°
			1,0	2,0	1,4	1,0
150	WLL 1 T	Brown / Violet	1,000	2,000	1,400	1,000
150	WLL 2 T	Brown / Green	2,000	4,000	2,800	2,000
200	WLL 1 T	Blue / Violet	1,000	2,000	1,400	1,000
200	WLL 2 T	Blue / Green	2,000	4,000	2,800	2,000
200	WLL 3 T	Blue / Yellow	3,000	6,000	4,200	3,000
250	WLL 2 T	Orange / Green	2,000	4,000	2,800	2,000
250	WLL 3 T	Orange / Yellow	3,000	6,000	4,200	3,000
300	WLL 2 T	Orange / Green	2,000	4,000	2,800	2,000
300	WLL 3 T	Orange / Yellow	3,000	6,000	4,200	3,000
400	WLL 2 T	Blue / Green	2,000	4,000	2,800	2,000
400	WLL 3 T	Blue / Yellow	3,000	6,000	4,200	3,000
400	WLL 4 T	Blue / Grey	4,000	8,000	5,600	4,000
500	WLL 3 T	Orange / Yellow	3,000	6,000	4,200	3,000
500	WLL 4 T	Orange / Grey	4,000	8,000	5,600	4,000
500	WLL 5 T	Orange / Red	5,000	10,000	7,000	5,000
600	WLL 3 T	Orange / Yellow	3,000	6,000	4,200	3,000
600	WLL 4 T	Orange / Grey	4,000	8,000	5,600	4,000
600	WLL 5 T	Orange / Red	5,000	10,000	7,000	5,000
600	WLL 6 T	Orange / Brown	6,000	12,000	8,400	6,000



MERTRA®

CW-1/30 Series

Lifting sling are manufactured to international standards.

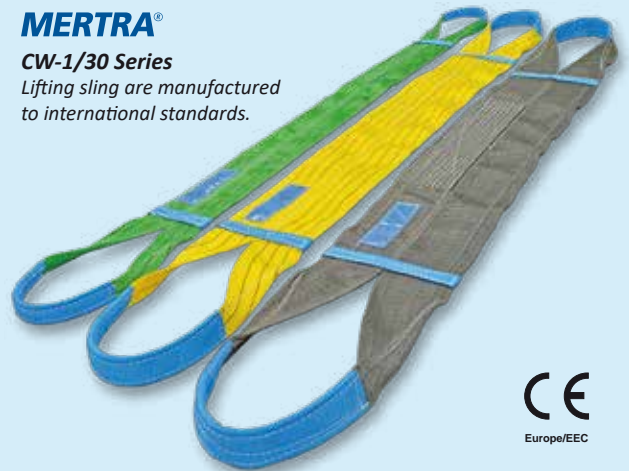

Europe/EEC



**MERTRA®**  
**MLL-2**  
Lowering-in Belts

**Model # MLL-2 Lowering-in Belts**

- Heavy duty polyester webbing for durability and strength
- Alloy steel end irons for greater strength with less weight
- Web coated with heavy duty coating
- Blue label with clear protective cover to protect data
- End irons painted
- Custom belts available for pipe diameters not listed
- Belts used around the world, in all types of climates, in sizes up to 60" Diameter pipe
- Head iron not included as pictured
- Lowering-in belt and head iron sold separately
- Max. working temp. 100°C ( 200°F ) Melting point 260°C ( 500°F )
- Excellant resistant to acids, oil, ultra violet ray, rot and mildew.
- Lightweight easy to handle, store and clean.
- No less of strength in water.
- Only 3% elongation.

part#	Max Pipe Diameter		Belt Width		Belt Length		Approximate Weight	Rated Capacity
	in	mm	in	mm	ft.- in	m		
MLL-0212	12"	305	12"	305	4' - 9"	1.45	14.5	21,772
MLL-0418	18"	457	18"	457	7' - 0"	2.13	23.6	33,112
MLL-0420	20"	508	18"	457	7' - 6"	2.29	24.9	33,112
MLL-0524	24"	610	24"	610	8' - 6"	2.59	36.7	43,998
MLL-0630	30"	762	30"	762	10' - 0"	3.05	40.8	55,338
MLL-0736	36"	914	36"	914	11' - 6"	3.51	54.4	66,224
MLL-0742	42"	1067	36"	914	13' - 6"	4.11	61.2	66,224
MLL-0748	48"	1219	36"	914	15' - 0"	4.57	70.3	66,224
MLL-0842	42"	1067	42"	1067	13' - 6"	4.11	68,0	77,564
MLL-0848	48"	1219	42"	1067	15' - 0"	4.57	77.1	77,564
MLL-0948	48"	1219	48"	1219	15' - 0"	4.57	90.7	88,450
MLL-0956	56"	1422	48"	1219	17' - 0"	5.18	100.0	88,450
MLL-1156	56"	1422	56"	1422	17' - 0"	5.18	113.0	103,418
MLL-1160	60"	1524	56"	1422	18' - 0"	5.49	122.0	103,418

**Safety factor**

- 5 to 1 design factor standard
- 7 to 1 design factors available upng request



Europe/EEC

**MERTRA®**

**MLL-2**  
Lifting sling and Head Iron are manufactured to international standards.



**Model # MLH**  
**Lifting Head Irons**

- Used to suspend lowering-in belts
- Alloy steel bail for greater strength with less weight
- Painted
- Stainless Steel Data plate
- Easy release hooks on one side

## Working Load Limit in Tonne

1-legged 	load capacity (kg)	Type of roundsling
	1.0	
	1,000	RS-5/01
	2,000	RS-5/02
	3,000	RS-5/03
	4,000	RS-5/04
	5,000	RS-5/05

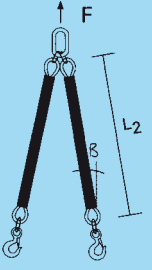
2-legged 	0-45° $\beta$ 45 - 60°		Type of roundsling
	1.4	1.0	
	1,400	1,000	RS-5/10
	2,800	2,000	RS-5/20
	4,200	3,000	RS-5/30
	5,600	4,000	RS-5/40
	7,000	5,000	RS-5/50

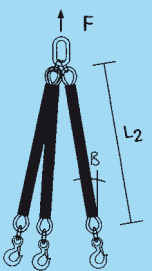
3-legged 	0-45° $\beta$ 45 - 60°		Type of roundsling
	2.1	1.5	
	2,100	1,500	RS-5/10
	4,200	3,000	RS-5/20
	6,300	4,500	RS-5/30
	8,400	6,000	RS-5/40
	10,500	7,500	RS-5/50

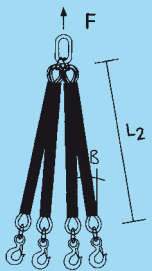
4-legged 	0-45° $\beta$ 45 - 60°		Type of roundsling
	2.1	1.5	
	2,100	1,500	RS-5/10
	4,200	3,000	RS-5/20
	6,300	4,500	RS-5/30
	8,400	6,000	RS-5/40
	10,500	7,500	RS-5/50

### HOW TO REQUIREMENT :

1. TYPE OF SLING (ROUND SLING/WEBBING SLING)
2. TYPE OF LEG SLING (1, 2, 3 or 4-LEGGED)
3. CAPACITY PER EACH LEG OR CAPACITY PER SET
4. WORKING LENGTH OF SLING
5. TYPE OF END FITTING

## 1, 2, 3 & 4 legged

**MERTRA®**

LS-1, 2, 3 & 4  
Legged sling are  
manufactured and tested  
according to international  
standards.



### FEATURE :

- Polyester roundsling assembly with metal components.
- One-, two-, three- or four-legged.

### SPECIFICATIONS :

- Each leg is protected by a sleeve.
- Standard Hook HS, other hooks on request.
- Lengths according to requirements.
- Light and easy to handle.
- Easy to control.

### CHARACTERISTICS

- Low elongation.
- Extremely wear-resistant.



**MERTRA®**

LS-4

4-Legged web-stop sling.



**MERTRA® WSG-1 Flat Lifting slings, Single eye.**

- Single eye polyester webbing sling.
- Working load limit WLL. 2.1-2.8 Tonne, Length 2-6 Mtr. ( on request ).
- Safety Factor ( S/F ) 7:1
- Protective pad, Rubber, PES. Webbing, Canvas.

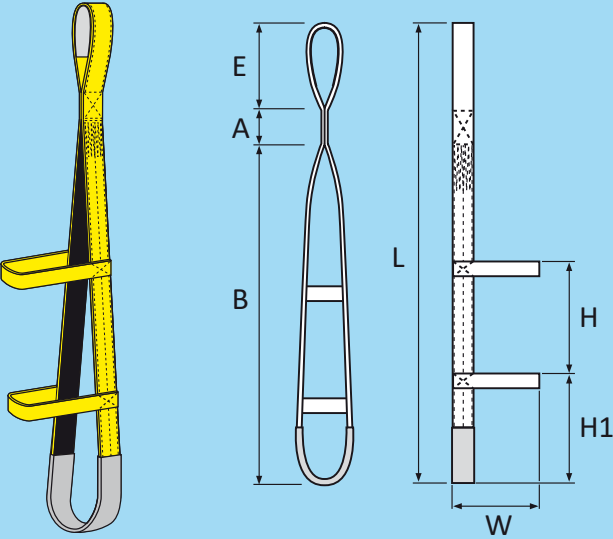

Type : WSG-1

**MERTRA®**  
WSG-1  
Single eye,  
Lifting glass

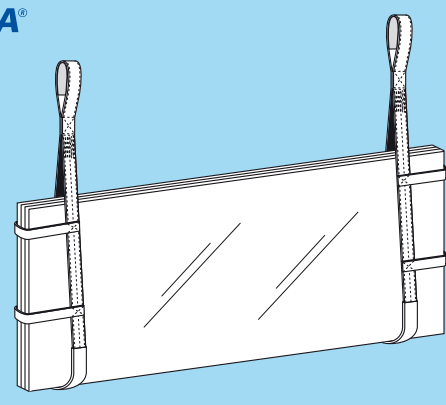

webbing width (mm)	SWL at basket lift	Colour	Working Load Limit with 2 sling
75	WLL 2.1 T	Yellow	4,200
100	WLL 2.8 T	Grey	5,600

**MERTRA® WSG-2 Flat Lifting slings, with 2-eyes**

- 2-eyes polyester webbing sling.
- Working load limit WLL. 2.8-5.6 Tonne, Length 2-6 Mtr. ( on request ).
- Safety Factor ( S/F ) 7:1
- Protective pad, Rubber, PES. Webbing, Canvas.

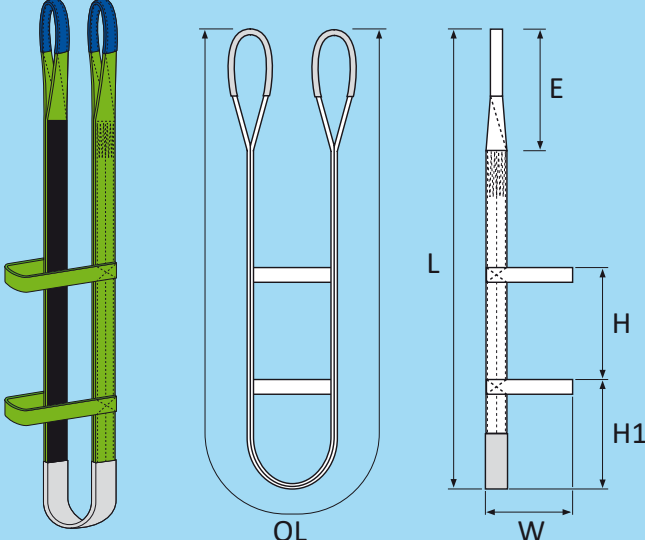

Type : WSG-2

**MERTRA®**  
WSG-2  
2-eye,  
Lifting glass

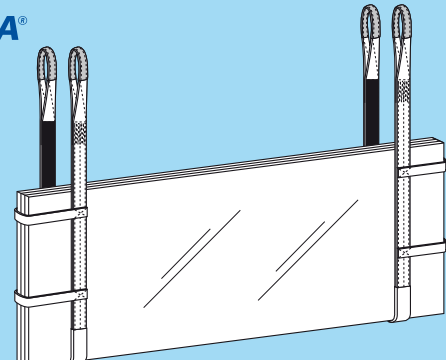

webbing width (mm)	SWL at basket lift	Colour	Working Load Limit with 2 sling
60	WLL 2.8 T	Green	5,600
75	WLL 4.2 T	Yellow	8,400
100	WLL 5.6 T	Grey	11,200



**MERTRA®**  
LB-R1  
Lifting beam, WLL 3 tonne

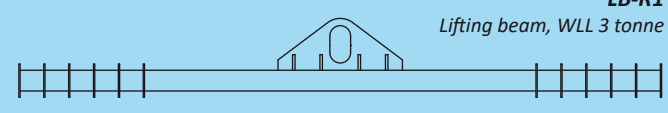

**MERTRA<sup>®</sup>**  
*Polyester Lashing System*



# Long Wide Handle Ratchet Strap 75 mm., 10,000 kgs.

**FEATURE :**

- ☑ Oversized plated steel ratchet handle for maximum leverage.
- ☑ High tenacity polyester webbing, Strong and abrasion resistant
- ☑ Super strong steel material and plated end fitting



**MERTRA®**  
**LSW7510L**



Item No.	Description	End Fitting	Length (M.) on Request	Load Capacity (Kgs.)	Break Strength (Kgs.)	Webbing color on Request
LSW7510L	75 mm., Long Wide Handle Ratchet Strap	Double J-Hook	1-20 Mtr.	5000	10000	Yellow
LSC7510L	75 mm., Long Wide Handle Ratchet Strap	Claw Hook	1-20 Mtr.	5000	10000	
LST7510L	75 mm., Long Wide Handle Ratchet Strap	Triangle Hook	1-20 Mtr.	5000	10000	
LSE7510L	75 mm., Long Wide Handle Ratchet Strap	Endless	1-20 Mtr.	5000	10000	



## Long Wide Handle Ratchet Strap 100 mm., 12,000 kgs.

**FEATURE :**

- ☑ Oversized plated steel ratchet handle for maximum leverage.
- ☑ High tenacity polyester webbing, Strong and abrasion resistant
- ☑ Super strong steel material and plated end fitting



**MERTRA®**  
**LSW9912L**

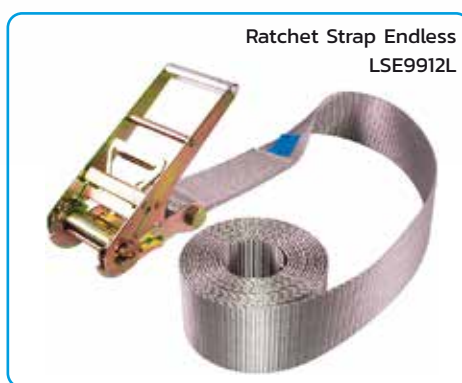
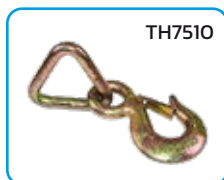

Item No.	Description	End Fitting	Length (M.) on Request	Load Capacity (Kgs.)	Break Strength (Kgs.)	Webbing color on Request
LSW9912L	100 mm., Long Wide Handle Ratchet Strap	Double J-Hook	1-20 Mtr.	6000	12000	
LSC9912L	100 mm., Long Wide Handle Ratchet Strap	Claw Hook	1-20 Mtr.	6000	12000	Gray
LST9912L	100 mm., Long Wide Handle Ratchet Strap	Triangle Hook	1-20 Mtr.	6000	12000	Yellow
LSE9912L	100 mm., Long Wide Handle Ratchet Strap	Endless	1-20 Mtr.	6000	12000	

# Heavy duty Ratchet Strap, Black edition 50 mm. 6,000 kgs.

**FEATURE :**

- ☑ Super strong ratchet mechanism with Ergo finger handle
- ☑ Black edition, Black epoxy powderd coat
- ☑ Double security lock
- ☑ High tenacity polyester webbing, Strong and abrasion resistant
- ☑ Super strong steel material and plated end fitting



**MERTRA®**  
**LSW5060B**

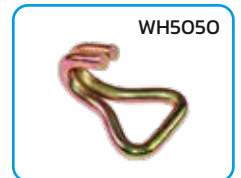

Item No.	Description	End Fitting	Length (M.) on Request	Load Capacity (Kgs.)	Break Strength (Kgs.)	Webbing color on Request
LSW5060B	50 mm., Black edition Heavy Ratchet Strap	Double J-Hook	1-20 Mtr.	3000	6000	
LSH5060B	50 mm., Black edition Heavy Ratchet Strap	Flat Hook	1-20 Mtr.	3000	6000	Orange
LSD5060B	50 mm., Black edition Heavy Ratchet Strap	D-Ring	1-20 Mtr.	3000	6000	Blue
LSF5060B	50 mm., Black edition Heavy Ratchet Strap	Flat Snap Hook	1-20 Mtr.	3000	6000	Black
LST5060B	50 mm., Black edition Heavy Ratchet Strap	Triangle Hook	1-20 Mtr.	3000	6000	Military Green
LSE5060B	50 mm., Black edition Heavy Ratchet Strap	Endless	1-20 Mtr.	3000	6000	

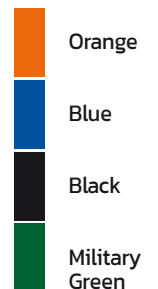

# Military Green Ratchet Strap, Heavy duty 50 mm. 6,000 kgs.

**FEATURE :**

- ☑ Super strong ratchet mechanism with Ergo finger handle
- ☑ Military green epoxy powderd coat,
- ☑ Double security lock
- ☑ High tenacity polyester webbing, Strong and abrasion resistant
- ☑ Super strong steel material and plated end fitting



**MERTRA®**  
**LSW5060M**

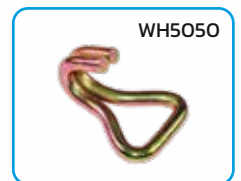

Item No.	Description	End Fitting	Length (M.) on Request	Load Capacity (Kgs.)	Break Strength (Kgs.)	Webbing color on Request
LSW5060M	50 mm., Military green Ratchet Strap	Double J-Hook	1-20 Mtr.	3000	6000	
LSH5060M	50 mm., Military green Ratchet Strap	Flat Hook	1-20 Mtr.	3000	6000	Orange
LSD5060M	50 mm., Military green Ratchet Strap	D-Ring	1-20 Mtr.	3000	6000	Blue
LSF5060M	50 mm., Military green Ratchet Strap	Flat Snap Hook	1-20 Mtr.	3000	6000	Black
LST5060M	50 mm., Military green Ratchet Strap	Triangle Hook	1-20 Mtr.	3000	6000	Military Green
LSE5060M	50 mm., Military green Ratchet Strap	Endless	1-20 Mtr.	3000	6000	

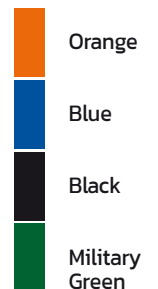



# Rubber Handle Ratchet Strap 50 mm. 5,000 kgs.

**FEATURE :**

- ☑ Long wide rubber handle, Comfortable overmoulded strong grip
- ☑ High tenacity polyester webbing, Strong and abrasion resistant
- ☑ Super strong steel material and plated end fitting



**MERTRA®**  
**LSW5050R**



Item No.	Description	End Fitting	Length (M.) on Request	Load Capacity (Kgs.)	Break Strength (Kgs.)	Webbing color on Request
LSW5050R	50 mm., Rubber Handle Ratchet Strap	Double J-Hook	1-20 Mtr.	2500	5000	
LSH5050R	50 mm., Rubber Handle Ratchet Strap	Flat Hook	1-20 Mtr.	2500	5000	
LSD5050R	50 mm., Rubber Handle Ratchet Strap	D-Ring	1-20 Mtr.	2500	5000	
LSK5050R	50 mm., Rubber Handle Ratchet Strap	Keeper Hook	1-20 Mtr.	2500	5000	
LSC5050R	50 mm., Rubber Handle Ratchet Strap	Claw Hook	1-20 Mtr.	2500	5000	
LSF5050R	50 mm., Rubber Handle Ratchet Strap	Flat Snap Hook	1-20 Mtr.	2500	5000	
LSN5050R	50 mm., Rubber Handle Ratchet Strap	Twisted Snap Hook	1-20 Mtr.	2500	5000	
LST5050R	50 mm., Rubber Handle Ratchet Strap	Triangle Hook	1-20 Mtr.	2500	5000	
LSE5050R	50 mm., Rubber Handle Ratchet Strap	Endless	1-20 Mtr.	2500	5000	

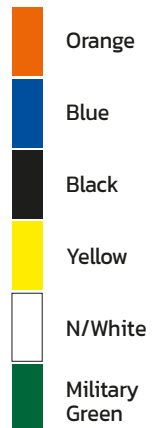

## Finger Handle Ratchet Strap 50 mm. 5,000 kgs.

**FEATURE :**

- ☑ Finger handle,  
Ergonomic design,  
Strong and easy to use
- ☑ High tenacity  
polyester webbing,  
Strong and abrasion resistant
- ☑ Super strong steel material  
and plated end fitting



**MERTRA®**  
**LSW5050F**



Item No.	Description	End Fitting	Length (M.) on Request	Load Capacity (Kgs.)	Break Strength (Kgs.)	Webbing color on Request
LSW5050F	50 mm., Finger Handle Ratchet Strap	Double J Hook	1-20 Mtr.	2500	5000	Orange
LSH5050F	50 mm., Finger Handle Ratchet Strap	Flat Hook	1-20 Mtr.	2500	5000	Blue
LSD5050F	50 mm., Finger Handle Ratchet Strap	D-Ring	1-20 Mtr.	2500	5000	Black
LSK5050F	50 mm., Finger Handle Ratchet Strap	Keeper Hook	1-20 Mtr.	2500	5000	Yellow
LSC5050F	50 mm., Finger Handle Ratchet Strap	Claw Hook	1-20 Mtr.	2500	5000	N/White
LSF5050F	50 mm., Finger Handle Ratchet Strap	Flat Snap Hook	1-20 Mtr.	2500	5000	Military Green
LSN5050F	50 mm., Finger Handle Ratchet Strap	Twisted Snap Hook	1-20 Mtr.	2500	5000	
LST5050F	50 mm., Finger Handle Ratchet Strap	Triangle Hook	1-20 Mtr.	2500	5000	
LSE5050F	50 mm., Finger Handle Ratchet Strap	Endless	1-20 Mtr.	2500	5000	

# Gradual Release Ratchet Strap 50 mm. 5,000 kgs.

**FEATURE :**

- ☑ Super strong ratchet mechanism with gradual release feature
- ☑ Duplicate secure protection, release strap controlled step by step for safety
- ☑ Overmolded finger trigger release pawl is sturdy, will not jam when under a heavy load
- ☑ Finger handle, Ergonomic design, Strong and easy to use
- ☑ High tenacity polyester webbing, Strong and abrasion resistant
- ☑ Super strong steel material and plated end fitting



**MERTRA®**  
**LSW5050G**



Item No.	Description	End Fitting	Length (M.) on Request	Load Capacity (Kgs.)	Break Strength (Kgs.)	Webbing color on Request
LSW5050G	50 mm., Gradual Release Ratchet Strap	Double J-Hook	1-20 Mtr.	2500	5000	Orange
LSH5050G	50 mm., Gradual Release Ratchet Strap	Flat Hook	1-20 Mtr.	2500	5000	Blue
LSD5050G	50 mm., Gradual Release Ratchet Strap	D-Ring	1-20 Mtr.	2500	5000	Black
LSC5050G	50 mm., Gradual Release Ratchet Strap	Claw Hook	1-20 Mtr.	2500	5000	Yellow
LSF5050G	50 mm., Gradual Release Ratchet Strap	Flat Snap Hook	1-20 Mtr.	2500	5000	N/White
LST5050G	50 mm., Gradual Release Ratchet Strap	Triangle Hook	1-20 Mtr.	2500	5000	Military Green
LSE5050G	50 mm., Gradual Release Ratchet Strap	Endless	1-20 Mtr.	2500	5000	



# Long Handle Ergo Ratchet Strap 50 mm. 5,000 kgs.

**FEATURE :**

- ☑ Long wide handle ratchet with double security lock
- ☑ Ergo ratchet buckle, Pull down operate feature to make the tie-down more easily
- ☑ Finger handle, Ergonomic design, Strong and easy to use
- ☑ High tenacity polyester webbing, Strong and abrasion resistant
- ☑ Super strong steel material and plated end fitting



**MERTRA®**  
**LSW5050X**



Item No.	Description	End Fitting	Length (M.) on Request	Load Capacity (Kgs.)	Break Strength (Kgs.)	Webbing color on Request
LSW5050X	50 mm., Long wide handle Ratchet Strap	Double J-Hook	1-20 Mtr.	2500	5000	
LSH5050X	50 mm., Long wide handle Ratchet Strap	Flat Hook	1-20 Mtr.	2500	5000	
LSD5050X	50 mm., Long wide handle Ratchet Strap	D-Ring	1-20 Mtr.	2500	5000	
LSC5050X	50 mm., Long wide handle Ratchet Strap	Claw Hook	1-20 Mtr.	2500	5000	
LSF5050X	50 mm., Long wide handle Ratchet Strap	Flat Snap Hook	1-20 Mtr.	2500	5000	
LST5050X	50 mm., Long wide handle Ratchet Strap	Triangle Hook	1-20 Mtr.	2500	5000	
LSE5050X	50 mm., Long wide handle Ratchet Strap	Endless	1-20 Mtr.	2500	5000	

**50 mm. 5000 kgs.,  
75 mm. 6800 kgs.,  
Lashing Winch**

**MERTRA®**

**LTW5060**

Ratchet strap with hook are  
manufactured and tested according  
to international standards.



**TW5050**

**LTW5050**  
B/S 5000 kgs.

50 mm. Trailer Winch with Hook  
Trailer Winch : TW5050  
End Fitting : WH5050  
Webbing : RIBBONS No. 6190  
Webbing Color

**TW5060**

**LTW5060**  
B/S 5000 kgs.

50 mm. Trailer Winch with Hook  
Trailer Winch : TW5060  
End Fitting : WH5050  
Webbing : RIBBONS No. 6190  
Webbing Color

**TW7570**

**LTW7570**  
B/S 6800 kgs.

75 mm. Trailer Winch with Hook  
Trailer Winch : TW7570  
End Fitting : WH7510  
Webbing : RIBBONS No. 6593  
Webbing Color

## 50 mm. 5000 kgs., High Tension Strap

**MERTRA®**

**LSV5050**

Polyester high tension strap with eye are  
manufactured and tested according  
to international standards.



### Vehicle Transport

**FEATURE :**

- MERTRA Lashing system with high tenacity polyester and high quality metal component.
- 1-Ply, 2-Ply Strap with hook (end fitting).
- Breaking strength (B/S) 5,000 kgs., Length 1-5 Mtr (on request).
- Available Webbing Color : ■ ■ ■ ■

**LSV5050A**  
B/S 5000 kgs.



**50 mm. 1-Ply High tension strap**  
End Fitting : SH1625  
Webbing : RIBBONS No. 6190T

**LSV5050B**  
B/S 5000 kgs.



**50 mm. 2-Ply High tension strap**  
End Fitting : SH1625  
Webbing : RIBBONS No. 6190T

**U-SHACKLE**



**10 mm. U-Shackle with Screw Pin**  
Size 10 mm. (3/8")  
Forged carbon steel

**SH-1625R**  
B/S 2500 kgs.



**Transport J-Hook, Square head**  
Size 16 mm. (5/8")  
High tensile carbon steel

**SH-1625F**  
B/S 2500 kgs.



**Transport J-Hook, Flat head**  
Size 16 mm. (5/8")  
High tensile carbon steel



**35 mm. 3000 kgs., Ratchet strap**

**MERTRA®**

**LS3530**

Ratchet strap with hook are  
manufactured and tested according  
to international standards.



**FEATURE :**

- MERTRA Lashing system with high tenacity polyester and high quality metal component.
- Ratchet strap with hook (end fitting) and Ratchet strap endless.
- Breaking strength (B/S) 3,000 kgs., Length 1-20 Mtr.

**LSW3530B**  
B/S 3000 kgs.



**35 mm. Ratchet strap with Hook**  
Ratchet Buckle : RB3530B  
End Fitting : WH3530  
Webbing : RIBBONS No. 5986

**SPECIFICATIONS :**

- Lashing webbing are produced from controlled 100% high tenacity polyester yarns.
- Metal components are selected to suit lashing webbing and meet international standard.
- Certified standard DIN V 61360 show at blue label.
- Webbing width 35mm.
- Standard J-Hook, other end fitting on request.
- Length according to requirement.
- Light weight and easy to operate.
- Low elongation.
- Available Webbing Color : ■ ■

**LSE3530B**  
B/S 3000 kgs.

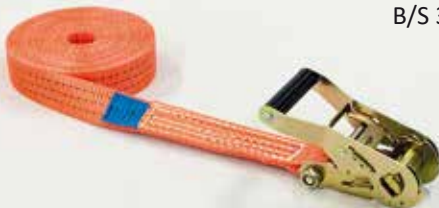

**35 mm. Ratchet strap Endless**  
Ratchet Buckle : RB3530B  
End Fitting : Endless  
Webbing : RIBBONS No. 5986

**LSL3530B**  
B/S 3000 kgs.



**35 mm. Ratchet strap with Loop Eyes**  
Ratchet Buckle : RB3530B  
End Fitting : Loop Eyes  
Webbing : RIBBONS No. 5986



**LSW3520P**  
B/S 2000 kgs.

**35 mm. Ratchet strap with Hook**  
Ratchet Buckle : RB3520P  
End Fitting : WH3530  
Webbing : RIBBONS No. 6044



**LSW3530**  
B/S 3000 kgs.

**35 mm. Ratchet strap with Hook**  
Ratchet Buckle : RB3530  
End Fitting : WH3530  
Webbing : RIBBONS No. 5986

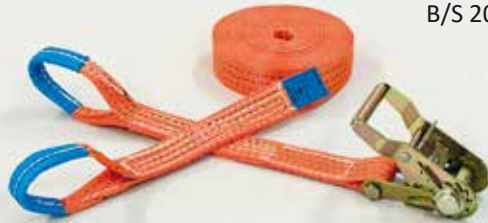

**LSL3520P**  
B/S 2000 kgs.

**35 mm. Ratchet strap with Loop Eyes**  
Ratchet Buckle : RB3520P  
End Fitting : Loop Eyes  
Webbing : RIBBONS No. 6044



**LSL3530**  
B/S 3000 kgs.

**35 mm. Ratchet strap with Loop Eyes**  
Ratchet Buckle : RB3530  
End Fitting : Loop Eyes  
Webbing : RIBBONS No. 5986



**LSE3520P**  
B/S 2000 kgs.

**35 mm. Ratchet strap Endless**  
Ratchet Buckle : RB3520P  
End Fitting : Endless  
Webbing : RIBBONS No. 6044



**LSE3530**  
B/S 3000 kgs.

**35 mm. Ratchet strap Endless**  
Ratchet Buckle : RB3530  
End Fitting : Endless  
Webbing : RIBBONS No. 5986



**MERTRA®**

**LOC4810**

*Lashing system with over center buckle are  
manufactured and tested according  
to international standards.*



Europe/EEC

**25 mm. 1000 kgs., 1500 kgs., Ratchet strap**

**MERTRA®**

**LS2510**

Ratchet strap with hook are  
manufactured and tested according  
to international standards.



**FEATURE :**

- MERTRA Lashing system with high tenacity polyester and high quality metal component.
- Ratchet strap with hook (end fitting) and Ratchet strap endless.
- Breaking strength (B/S) 1,000 kgs., 1,500 kgs., Length 1-20 Mtr.
- Available Webbing Color : ■ ■ ■ ■ ■ ■

**LSW2510B**  
B/S 1000 kgs.



**25 mm. Ratchet strap with Hook**  
Ratchet Buckle : RB2510B  
End Fitting : WH2515  
Webbing : RIBBONS No. 6666

**LSS2510B**  
B/S 1000 kgs.



**25 mm. Ratchet strap with S-Hook**  
Ratchet Buckle : RB2510B  
End Fitting : SH2509B  
Webbing : RIBBONS No. 6666

**LSL2510B**  
B/S 1000 kgs.



**25 mm. Ratchet strap with Loop Eyes**  
Ratchet Buckle : RB2510B  
End Fitting : Loop Eyes  
Webbing : RIBBONS No. 6666

**LSE2510B**  
B/S 1000 kgs.



**25 mm. Ratchet strap Endless**  
Ratchet Buckle : RB2510B  
End Fitting : Endless  
Webbing : RIBBONS No. 6666



**LSW2515P**  
B/S 1500 kgs.



**25 mm. Ratchet strap with Hook**  
Ratchet Buckle : RB2515P  
End Fitting : WH2515  
Webbing : RIBBONS No. 1500T

**LSS2515P**  
B/S 1500 kgs.



**25 mm. Ratchet strap with S-Hook**  
Ratchet Buckle : RB2515P  
End Fitting : SH2511  
Webbing : RIBBONS No. 1500T

**LSL2515P**  
B/S 1500 kgs.



**25mm. Ratchet strap with Loop Eyes**  
Ratchet Buckle : RB2515P  
End Fitting : Loop Eyes  
Webbing : RIBBONS No. 1500T

**LSE2515P**  
B/S 1500 kgs.



**25 mm. Ratchet strap Endless**  
Ratchet Buckle : RB2515P  
End Fitting : Endless  
Webbing : RIBBONS No. 1500T

**LSW2515R**  
B/S 1500 kgs.



**25 mm. Ratchet strap with Hook**  
Ratchet Buckle : RB2515  
End Fitting : WH2515  
Webbing : RIBBONS No. 1500T

**LSS2515R**  
B/S 1500 kgs.



**25 mm. Ratchet strap with S-Hook**  
Ratchet Buckle : RB2515  
End Fitting : SH2511  
Webbing : RIBBONS No. 1500T

**LSL2515R**  
B/S 1500 kgs.



**25 mm. Ratchet strap with Loop Eyes**  
Ratchet Buckle : RB2515  
End Fitting : Loop Eyes  
Webbing : RIBBONS No. 1500T

**LSE2515R**  
B/S 1500 kgs.



**25 mm. Ratchet strap Endless**  
Ratchet Buckle : RB2515  
End Fitting : Endless  
Webbing : RIBBONS No. 1500T

**25 mm. 250-1200 kgs., Tie Down Strap**



**MERTRA®**

**CS2505**

*Tie down strap with hook are  
manufactured and tested according  
to international standards.*



**FEATURE :**

- MERTRA Lashing system with high tenacity polyester and high quality metal component.
- Tie down strap with hook (end fitting) and Tie down strap endless.
- Breaking strength (B/S) 250 kgs.- 1,200 kgs., Length 1-20 Mtr.



**CSE2505**  
B/S 500 kgs.

**25 mm. Strap Endless**  
Cam Buckle : CB2505A  
End Fitting : Endless  
Webbing : RIBBONS No. 1000T

**SPECIFICATIONS :**

- Lashing webbing are produced from controlled 100% high tenacity polyester yarns.
- Metal components are selected to suit lashing webbing and meet international standard.
- Certified standard DIN V 61360 show at blue label.
- Webbing width 25mm., 35mm., 50mm.
- Standard J-Hook, other end fitting on request.
- Length according to requirement.
- Light weight and easy to operate.
- Low elongation.
- Available Webbing Color :



**CSW2505**  
B/S 500 kgs.

**25 mm. Strap with Hook**  
Cam Buckle : CB2505A  
End Fitting : WH2515  
Webbing : RIBBONS No. 1000T



**CSS2505**  
B/S 500 kgs.

**25mm. Strap with S-Hook**  
Cam Buckle : CB2505A  
End Fitting : SH2509  
Webbing : RIBBONS No. 1000T

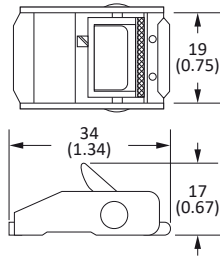

**CB2001**

**20 mm. Cam Buckle**  
Light Duty  
B/S : 100 kgs/220 lbs

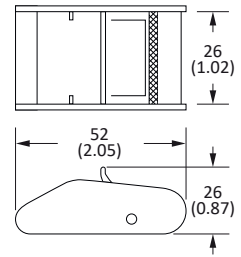

**CB2504**

**25 mm. Cam Buckle**  
Heavy Duty  
B/S : 450 kgs/990 lbs

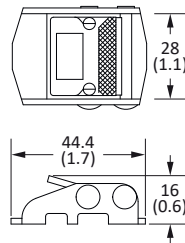

**CB2502**

**25 mm. Steel Cam Buckle**  
Light Duty  
B/S : 250 kgs/550 lbs

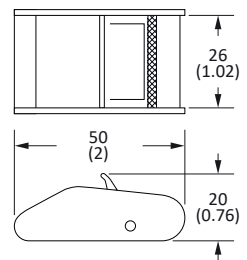
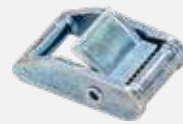

**CB2505**

**25 mm. Cam Buckle**  
Heavy Duty  
B/S : 500 kgs/1,100 lbs

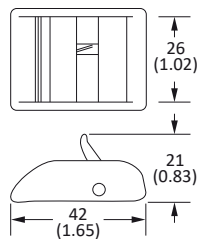

**CB2503**

**25 mm. Cam Buckle**  
Light Duty  
B/S : 350 kgs/770 lbs

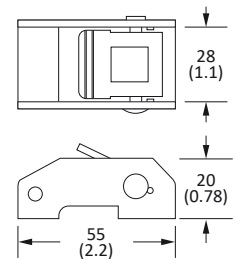

**CB2506**

**25 mm. Steel Cam Buckle**  
Heavy Duty  
B/S : 600 kgs/1,320 lbs

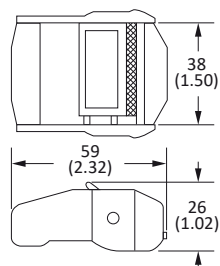

**CB3507**

**35 mm. Cam Buckle**  
Heavy Duty  
B/S : 700 kgs/1,540 lbs

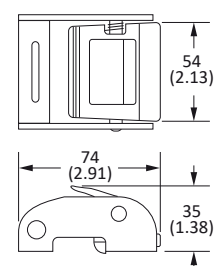

**CB5012**

**50 mm. Cam Buckle**  
Heavy Duty  
B/S : 1,135 kgs/2,500 lbs



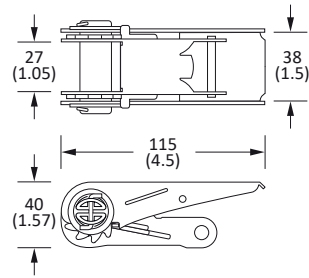

**RB2510C**

**25 mm. Ratchet Buckle**  
Light Duty  
B/S : 900 kgs/1,980 lbs

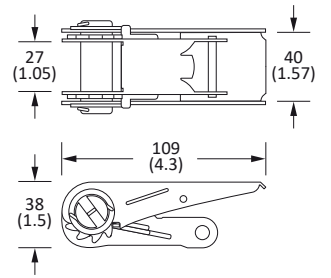

**RB2510B**

**25 mm. Ratchet Buckle**  
Light Duty, Black Epoxy Coated  
B/S : 900 kgs/1,980 lbs

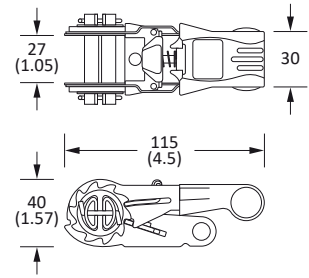

**RB2510R**

**25 mm. Ratchet Buckle, Rubber Handle**  
Light Duty  
B/S : 900 kgs/1,980 lbs

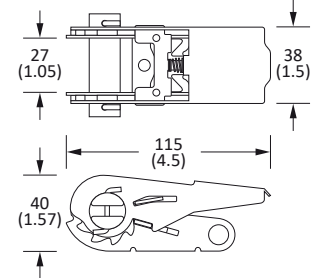

**RB2515C**

**25 mm. Ratchet Buckle**  
Heavy Duty  
B/S : 1,500 kgs/3,300 lbs

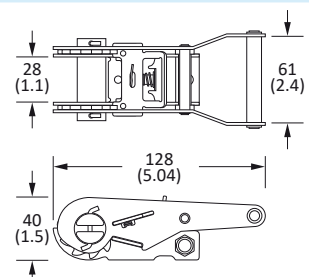

**RB2515R**

**25 mm. Ratchet Buckle**  
Wide Handle  
B/S : 1,500 kgs/3,300 lbs

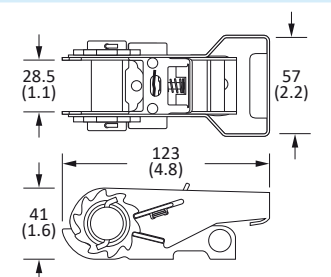

**RB2515P**

**25 mm. Ratchet Buckle**  
One Piece Handle  
B/S : 1,500 kgs/3,300 lbs

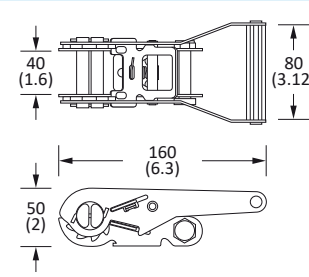

**RB3530B**

**35 mm. Ratchet Buckle**  
Plastic Black Handle  
B/S : 3,000 kgs/6,600 lbs

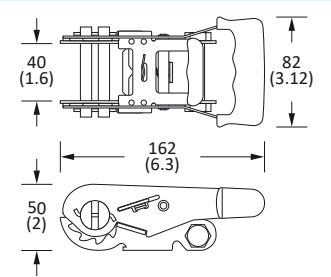

**RB3530R**

**35 mm. Ratchet Buckle**  
Wide Rubber Handle  
B/S : 3,000 kgs/6,600 lbs

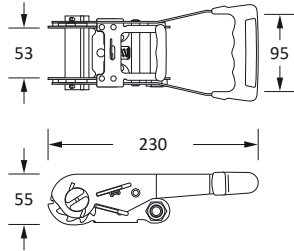

**RB5050R**

**50 mm. Rubber Handle Ratchet Buckle**  
Double Security Lock  
B/S : 5,000 kgs/11,000 lbs

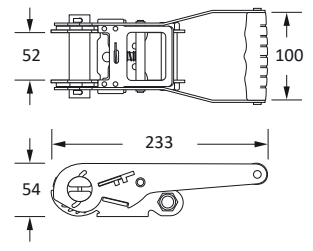

**RB5050F**

**50 mm. Finger Handle Ratchet Buckle**  
Double Security Lock  
B/S : 5,000 kgs/11,000 lbs

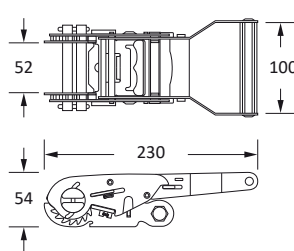

**RB5050L**

**50 mm. Lock-Key Ratchet Buckle**  
Double Security Lock  
B/S : 5,000 kgs/11,000 lbs

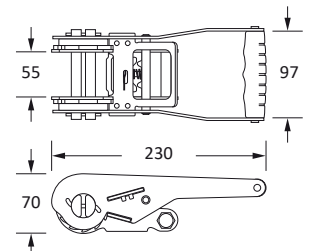

**RB5050T**

**50 mm. Automatic Tension Adjustment Ratchet Buckle**  
Double Security Lock  
B/S : 5,000 kgs/11,000 lbs

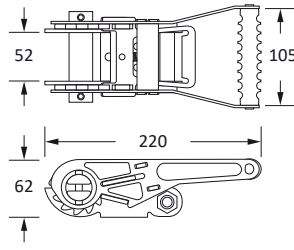

**RB5060B**

**50 mm. Ratchet Buckle, Heavy Duty**  
Long Handle, Double Security Lock  
Black Epoxy Coated  
B/S : 6,000 kgs/13,200 lbs

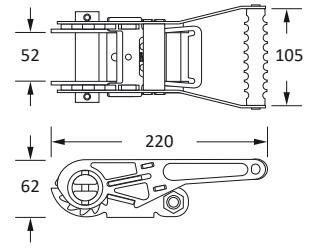

**RB5060M**

**50 mm. Ratchet Buckle, Heavy Duty**  
NATO BUCKLE, Double Security Lock  
Military Green Epoxy Coated  
B/S : 6,000 kgs/13,200 lbs

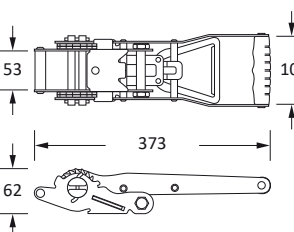

**RB5050X**

**50 mm. Long Handle Ergo Ratchet Buckle, Pull Type**  
Double Security Lock  
B/S : 5,000 kgs/11,000 lbs

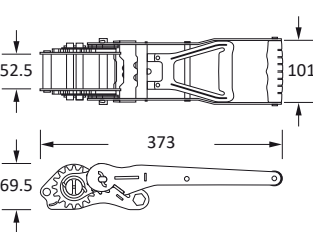

**RB5050D**

**50 mm. Gear-Drive Ratchet Buckle, Pull Type**  
Extra Heavy Duty  
Long Handle, Double Security Lock  
B/S : 5,000 kgs/11,000 lbs

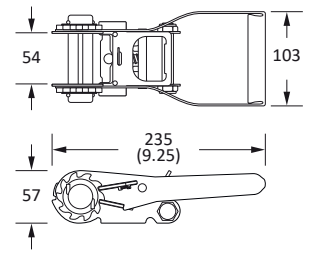
**RB5060P**

**50 mm. Ratchet Buckle, Heavy Duty**  
One Piece Long Wide Handle, Easy Release  
Double Security Lock  
B/S : 6,000 kgs/13,200 lbs

**RB5050G**

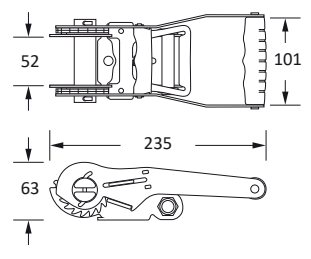
**50 mm. Gradual Release Ratchet Buckle, Heavy Duty**  
Double Security Lock  
B/S : 5,000 kgs/11,000 lbs

**RB5050M**

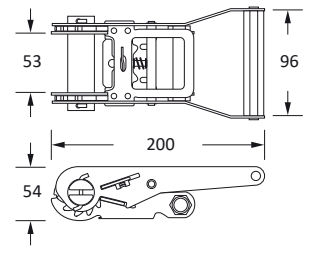
**50 mm. Medium Handle Ratchet Buckle**  
Wide Handle, Double Security Lock  
B/S : 5,000 kgs/11,000 lbs

**RB5050S**

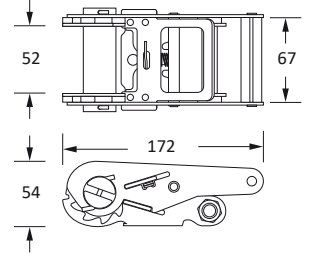
**50 mm. Short Handle Ratchet Buckle**  
B/S : 5,000 kgs/11,000 lbs

**RB5020R**

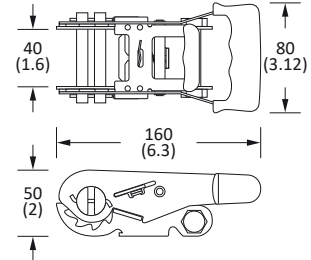
**50 mm. Light Duty Rubber Handle Ratchet Buckle**  
B/S : 2,000 kgs/4,400 lbs



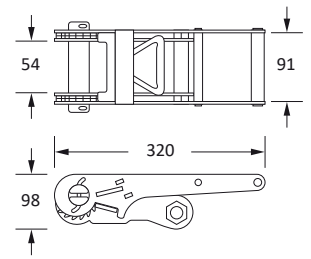

**RB5050H**

**50 mm. Gradual Release Ratchet Buckle, Heavy Duty**  
Double Security Lock, Rubber Handle  
B/S : 5,000 kgs/11,000 lbs

**RB7510L**

**75 mm. Ratchet Buckle, Heavy Duty**  
B/S : 10,000 kgs/22,000 lbs

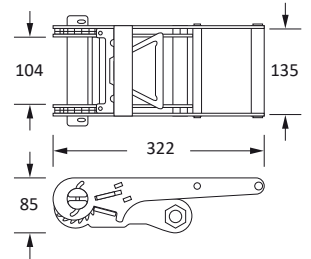
**RB9912L**

**100 mm. Ratchet Buckle, Heavy Duty**  
B/S : 12,000 kgs/26,400 lbs



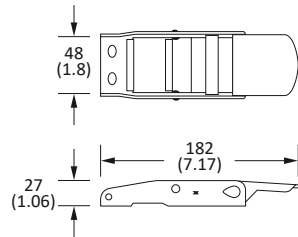

**OCB4810**

**50 mm. Overcenter Buckle**  
B/S : 800 kgs/1,760 lbs

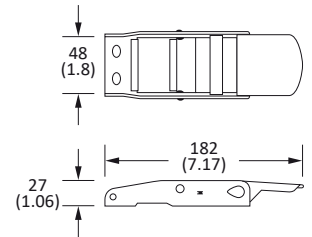

**OCB4810S**

**50 mm. Overcenter Buckle, Stainless Steel**  
B/S : 800 kgs/1,760 lbs

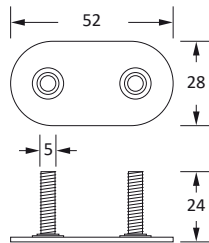

**OCB4810FP**

**Fixing Plate**  
Suitable for OCB4810, OCB4810S

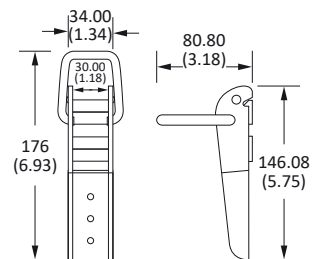

**OCB2520**

**25 mm. Overcenter Buckle**  
B/S : 2,000 kgs/4,400 lbs

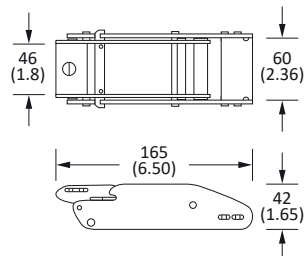

**OCB4820**

**48 mm. Overcenter Buckle**  
B/S : 2,270 kgs/5,000 lbs

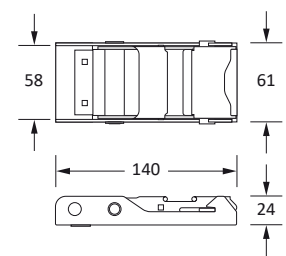

**OCB5020**

**50 mm. Overcenter Buckle**  
B/S : 2,000 kgs/4,400 lbs

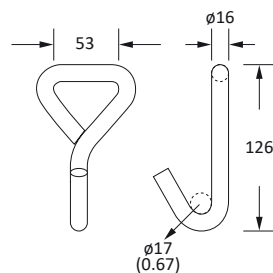

**WJ5050**

**50 mm. Single J Hook**  
B/S : 5,000 kgs/11,000 lbs

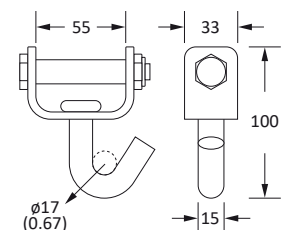

**WS5050**

**50 mm. Swivel J Hook with Bolt & Nut & Tube**  
B/S : 5,000 kgs/11,000 lbs

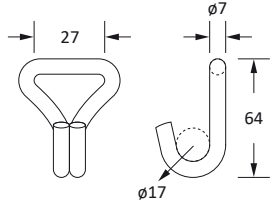

**WH2515**

**25 mm. Double J Hook**  
B/S : 1,360 kgs/3,000 lbs

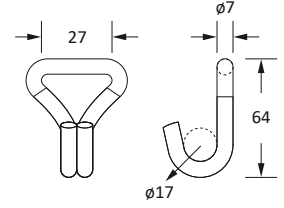

**WH2515R**

**25 mm. Double J Hook**  
Black PVC Coated  
B/S : 1,360 kgs/3,000 lbs

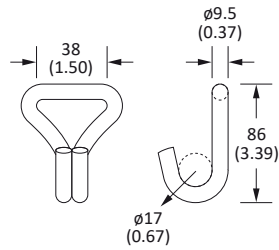

**WH3530**

**35 mm. Double J Hook**  
B/S : 3,000 kgs/6,600 lbs

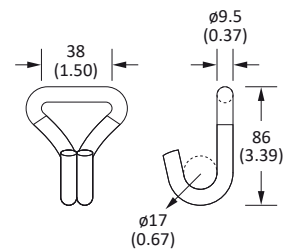

**WH3530R**

**35 mm. Double J Hook**  
Black PVC Coated  
B/S : 3,000 kgs/6,600 lbs

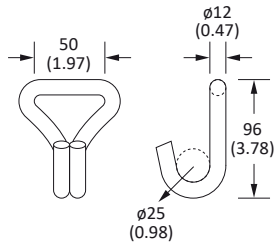

**WH5050**

**50 mm. Double J Hook**  
B/S : 5,000 kgs/11,000 lbs

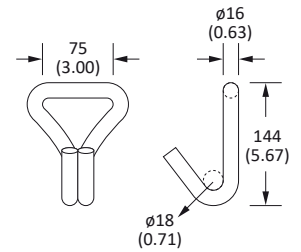

**WH7510**

**75 mm. Double J Hook**  
B/S : 10,000 kgs/22,000 lbs

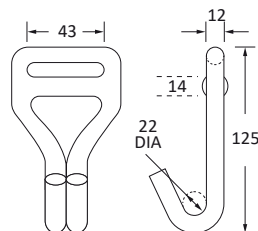

**WH4250N**

**42 mm. Double J Hook**  
No Sewn Hook  
B/S : 5,000 kgs/11,000 lbs

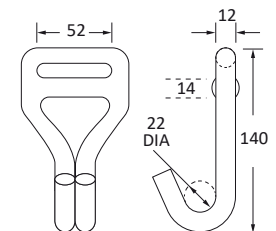

**WH5050N**

**50 mm. Double J Hook**  
No Sewn Hook  
B/S : 5,000 kgs/11,000 lbs

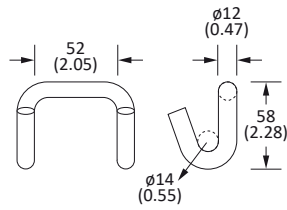

**CH5050**

**50 mm. Claw Hook**  
B/S : 5,000 kgs/11,000 lbs

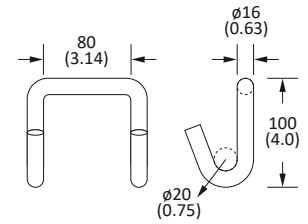

**CH7510**

**75 mm. Claw Hook**  
B/S : 10,000 kgs/22,000 lbs

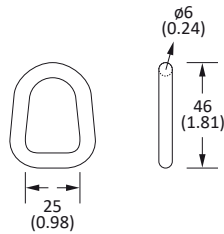

**DH2508**

**25 mm. D-Ring**  
B/S : 800 kgs/1,760 lbs

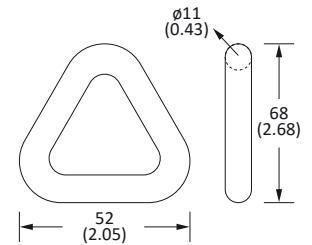

**DH5050**

**50 mm. D-Ring**  
B/S : 5,000 kgs/11,000 lbs

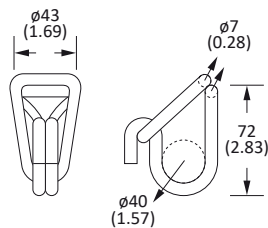

**KH3530**

**35 mm. Hook & Keeper**  
B/S : 3,000 kgs/6,600 lbs

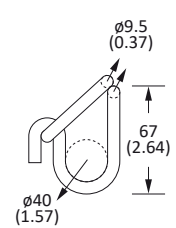

**KH5050**

**50 mm. Hook & Keeper**  
B/S : 5,000 kgs/11,000 lbs

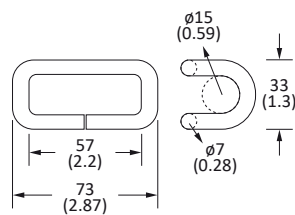

**RH5015**

**50 mm. Close Rave Hook**  
B/S : 1,500 kgs/3,300 lbs

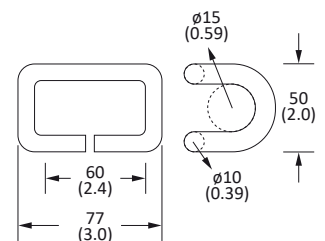

**RH5015A**

**50 mm. Close Rave Hook**  
B/S : 1,500 kgs/3,300 lbs



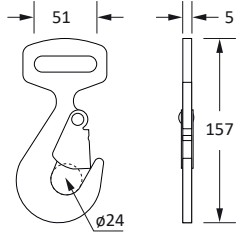

**SF5050**

**50 mm. Flat Snap Hook**  
B/S : 5,000 kgs/11,000 lbs

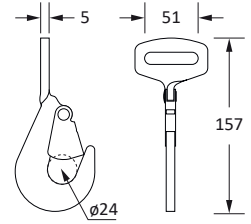

**ST5050**

**50 mm. Twisted Snap Hook**  
B/S : 5,000 kgs/11,000 lbs

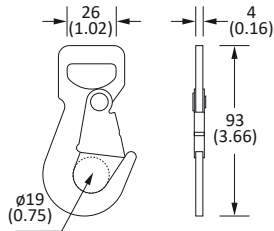

**SF2515**

**25 mm. Flat Snap Hook**  
B/S : 1,500 kgs/3,300 lbs

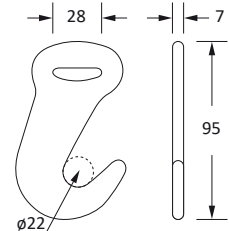

**FH2520**

**25 mm. Flat Hook**  
B/S : 2,000 kgs/4,400 lbs

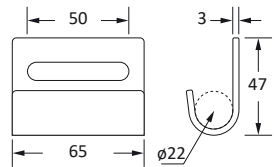

**FH5008**

**50 mm. Flat Hook**  
B/S : 800 kgs/1,760 lbs

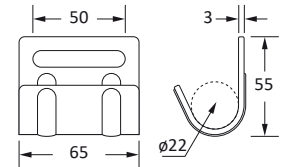

**FH5008S**

**50 mm. Flat Hook, Stainless Steel**  
B/S : 800 kgs/1,760 lbs

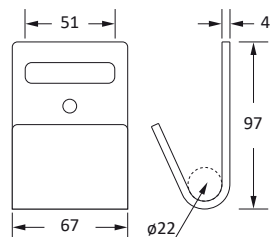
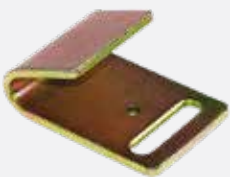

**FH5050**

**50 mm. Flat Hook**  
B/S : 5,000 kgs/11,000 lbs

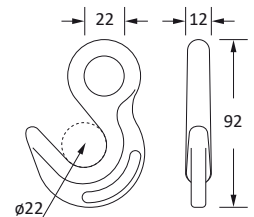

**EH5050**

**50 mm. Forged Hook**  
B/S : 5,000 kgs/11,000 lbs

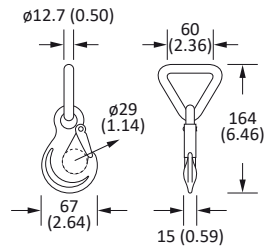

**TH5050**

**50 mm. Hook with D-Ring**  
B/S : 5,000 kgs/11,000 lbs

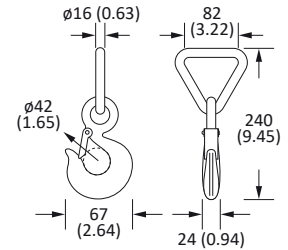

**TH7510**

**75 mm. Hook with D-Ring**  
B/S : 10,000 kgs/22,000 lbs

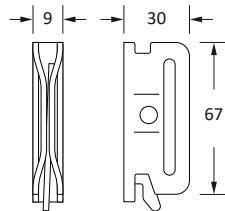

**EF5016**

**50 mm. End fitting ( E-Track )**  
B/S : 1,596 kgs/3,511 lbs

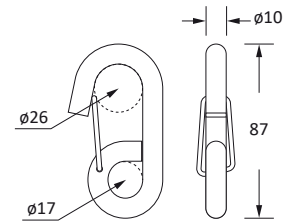

**SL2510**

**25 mm. Snap Hook**  
B/S : 1,200 kgs/2,640 lbs

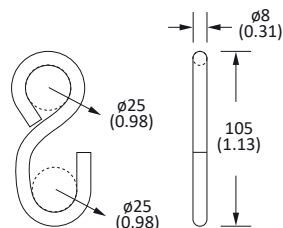

**SH2509B**

**25 mm. S Hook**  
Black PVC Coated  
B/S : 900 kgs/1,980 lbs

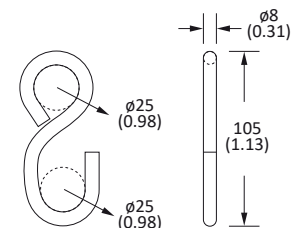

**SH2509C**

**25 mm. S Hook**  
B/S : 900 kgs/1,980 lbs

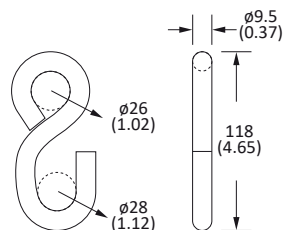

**SH2511B**

**25 mm. S Hook**  
Black PVC Coated  
B/S : 1,100 kgs/2,420 lbs

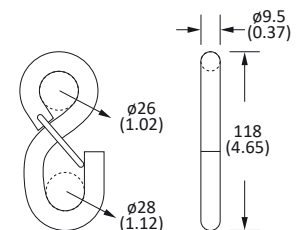

**SH2511L**

**25 mm. S Hook with Safety Latch**  
Black PVC Coated  
B/S : 1,100 kgs/2,420 lbs

# PRODUCT RANGE

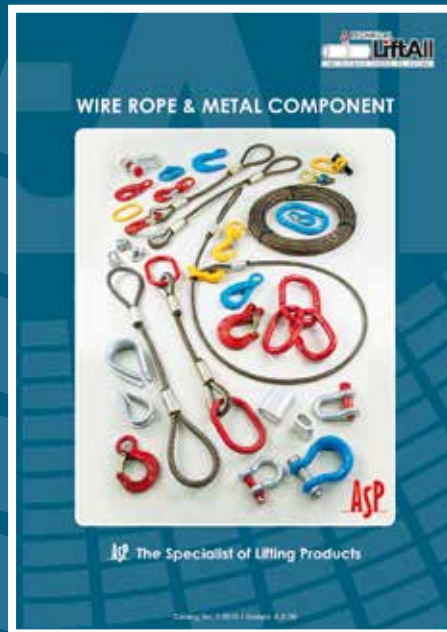
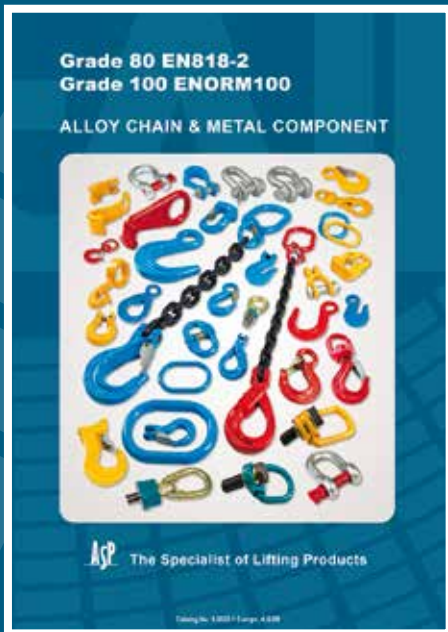
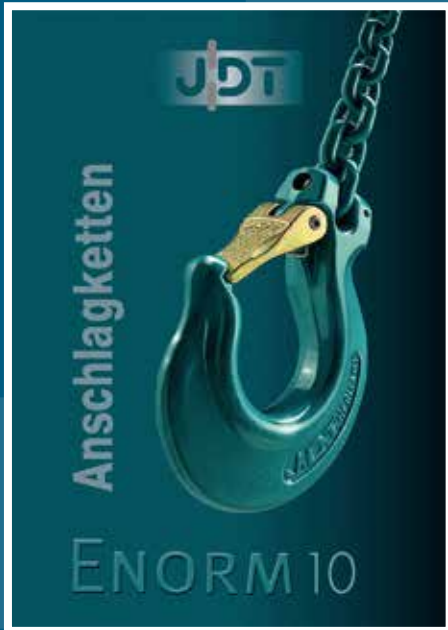

**TECHNICAL LIFT-ALL CO., LTD.**

124/137/7 Tiwanon Rd., T. Taladkwan, A. Muang, Nonthaburi 11000

Tel. 02-968-1896-8 Fax : 02-968-1899

E-mail : [technical@liftall.co.th](mailto:technical@liftall.co.th), [sales@liftall.co.th](mailto:sales@liftall.co.th)



[www.liftall.co.th](http://www.liftall.co.th)



@liftall



liftalofficial



lift\_all



Technical Lift All



liftalofficial